

Email

[Create New Account](#)

Password

[Forgot Password](#)

[Login](#)

When logged in - this box changes to:
"logged in as <user>" - link to logout

[Search](#)

[Advanced Search](#)

[Home](#)

[Artist A-Z](#)

Common tabs, everyone has home and artist A-Z access

Only registered users have a profile

Only Registered Artists have bids and calendar

Only Registered Employers own projects, a shortlist and contracts

On this page:

- * *what the site does - and for who.*
- * *how it benefits artists and employers*
- * *testimonials*
- * *mini (or partial) screenshots (projects, bids, endorsements, etc.)*
- * *big extra link to sign-up*
- * *big extra link to artist A-Z*

Email

Password

[Login](#)

[Create New Account](#)

[Forgot Password](#)

[Search](#)

[Advanced Search](#)

[Home](#)

[Artist A - Z](#)

[Registration](#)

Registration

I am an: Artist Employer Both

Name:

Email:

Password:

Confirm Password:

How did you hear about us:

I have read and agree to the [Terms and Conditions](#):

[Submit](#)

[Cancel](#)

Email

[Create New Account](#)

Password

[Forgot Password](#)

[Login](#)

[Search](#)

[Advanced Search](#)

[Home](#)

[Artist A - Z](#)

[Forgot Password](#)

Forgot Password

Email:

[Submit](#)

[Cancel](#)

Email

[Create New Account](#)

Password

[Forgot Password](#)

[Login](#)

Logged in as: matthew@mpc.com

Account type: Employer

[Log out](#)

[Search](#)

[Advanced Search](#)

Simplified version of projects page.

No "contract" or "message" columns (or links) on this page.

No date filters!

"Show projects" combo options: "all, proj_1, proj_2.. proj_n"

When ALL projects selected in combo - maybe we can have pagination ??? - please advise ?? ...

[Home](#)

[Artist A - Z](#)

[Profile](#)

[Projects](#)

[Shortlist](#)

[Contracts](#)

Listing projects for The Moving Picture Company

[How does the bidding system work ?](#)

[Create New Project](#)

Show Projects

Project: [Harry Potter and the Philosophers Stone \(HP1\)](#) - Live Action Feature - 2 Sep 07 - 1 Feb 09

Adventures of boy wizard at new school. Starring Dan Radcliffe

[Delete Project](#) - [Create New Position](#)

Show Positions

Position: [texture artist](#) - ([Edit](#) | [Delete](#)) 5 places - 0 final - 1 accepted - 2 open

notes for this artist appears as floater

Artist	Bid	Status	Action
James McCarter	USD 1200.00 pcm 13 Oct - 20 Dec 08	Open	Retract
Matt Hicks	GBP 1100.00 pcm 13 Oct - 20 Dec 08	Accepted	Finalize Retract
Olivier Junquet	CAD 1200.00 pcm 13 Oct - 20 Dec 08	Open	Retract
Simon Clutterbuck	USD 1200.00 pcm 13 Oct - 20 Dec 08	Declined	

Position: [lead animator](#) - ([Edit](#) | [Delete](#)) 5 places - 0 final - 1 accepted - 2 open

Artist	Bid	Status	Action
James McCarter	USD 1200.00 pcm 13 Oct - 20 Dec 08	Open	Retract
Olivier Junquet	CAD 1200.00 pcm 13 Oct - 20 Dec 08	Finalized	

Project: [Charlie and the Chocolate Factory \(CCF\)](#) - Live Action Feature - 2 Sep 07 - 1 Feb 09

Adventures of poor boy with sugar addiction.

[Delete Project](#) - [Create New Position](#)

Show Positions

Position: [roto artist](#) - ([Edit](#) | [Delete](#)) 5 places - 0 final - 1 accepted - 2 open

Artist	Bid	Status	Action
James McCarter	USD 1200.00 pcm 13 Oct - 20 Dec 08	Open	Retract
Matt Hicks	GBP 1100.00 pcm 13 Oct - 20 Dec 08	Accepted	Finalize Retract
Olivier Junquet	CAD 1200.00 pcm 13 Oct - 20 Dec 08	Open	Retract
Simon Clutterbuck	USD 1200.00 pcm 13 Oct - 20 Dec 08	Declined	

<<< [PREVIOUS](#) Showing: 2 to 3 of 7 projects [NEXT](#) >>>

Search

[Advanced Search](#)

Simplified version of bids page.

No "contract" or "message" columns (or links) on this page.

No date filters!

"Show Bids" combo options: "all,open, accepted, finalized"

Position/project and bid amount columns - **merged into one column**, which links to bid detail page --- /bids/1571

[Home](#)

[Artist A - Z](#)

[Profile](#)

Bids

[How does the bidding system work ?](#)

Show Bids:

Bids for Fred Chapman			
Bidder	Bid	Status	Action
The Moving Picture Company	Texture Artist - Kingdom of Heaven USD 1200.00 pcm - 13 Oct - 20 Dec 08	Open	Accept Decline
Animal Logic	Animator - Batman 1 USD 1200.00 pcm - 13 Oct - 20 Dec 08	Accepted	Re-open Decline
Sony Pictures	Lead Animator - Once Upon a Time USD 1200.00 pcm - 13 Oct - 20 Dec 08	Finalized	
The Moving Picture Company	Matte Painter - Kingdom of Heaven USD 1200.00 pcm - 13 Oct - 20 Dec 08	Declined	Delete

Email

[Create New Account](#)

Password

[Forgot Password](#)

[Login](#)

[Search](#)

[Advanced Search](#)

[Home](#)

[Artist A - Z](#)

[Advanced Search](#)

Advanced Search

Name

Name:

Availability

From: 

To: 

Match: 

Skills

[List](#)

Credits

Project:

Keywords:

Location

I am interested in artists who can :

Commute: 

To:



Relocate: 

Work Remotely: 

Operating System: Mac Win Linux

[Clear](#)

[Search](#)

Search

[Advanced Search](#)

[Home](#)

[Artist A - Z](#)

[Profile](#)

[Bids](#)

[Projects](#)

[Shortlist](#)

[Contracts](#)

Account

[Contact](#)

[Location](#)

[Skills](#)

[Credits](#)

[Gallery](#)

[Diary](#)

[Qualifications](#)

[Reputation](#)

[Representation](#)

Julian Mann's Account



Name: Julian Mann

Email: julian.mann@gmail.com

Password: *****

Account Type: Artist & Employer

[Edit](#)

Edit Your Account

First Name:

Last Name:

Email:

Password:

Confirm Password:

There are some restrictions to changing your account type, especially if you have bid activity. Please see the [FAQ](#) for details.

Account Type: Artist Employer Both

Save Changes

or [Cancel](#)

Update Your Photo



You can upload a small photo (GIF, JPG, or PNG), which will be cropped square if necessary.

Browse

Upload Now

AJAX -

In its normal state, this page only shows the top div "Julian Mann's Account"

When the edit button is clicked, it is replaced by bottom div "Edit your account an update photo"

[Search](#)

[Advanced Search](#)

[Home](#)

[Artist A - Z](#)

[Profile](#)

[Bids](#)

[Projects](#)

[Shortlist](#)

[Contracts](#)

[Account](#)

[Contact](#)

[Location](#)

[Skills](#)

[Credits](#)

[Gallery](#)

[Diary](#)

[Qualifications](#)

[Reputation](#)

[Representation](#)

Julian Mann's Contact Details

Address 1: 4596 Rue de Lanaudiere

Address 2:

Town: Montreal

State / Region: Quebec

Post Code: H2J 3P7

Country: Canada

Phone: +1 514 524 0047

Skype: julian.mann

Speaks: English & French

AJAX -

In its normal state, this page only shows the top div "Julian Mann's Contact Details"

When the edit button is clicked, it is replaced by bottom div "Edit Julian Mann's Contact Details"

[Edit](#)

Edit Julian Mann's Contact Details

Address and Contact information is optional, but you are an artist, you will need an address if you want to accept a bid from an employer.

Address 1:

Address 2:

Town:

State / Region:

Post Code:

Country:

Phone:

Skype:

Spoken Languages:

[Save Changes](#) or [Cancel](#)

Search

[Advanced Search](#)

[Home](#)

[Artist A - Z](#)

[Profile](#)

[Bids](#)

[Projects](#)

[Shortlist](#)

[Contracts](#)

[Account](#)

[Contact](#)

[Location](#)

[Skills](#)

[Credits](#)

[Gallery](#)

[Diary](#)

[Qualifications](#)

[Reputation](#)

[Representation](#)

Julian Mann's Location

Place of Work

I can commute to London, UK
I am not prepared to relocate
I can work remotely. - (I have computers running Mac OS and Windows)
My Prefereed Currency is (Euro)

[Edit](#)

AJAX - When the user clicks edit button, The "location" div should be replaced with the "edit location" div.

Edit Place of Work

I can commute:

to:

Country:

I am prepared to relocate:

I can work remotely:

My computers run: Win Mac Linux

My preferred currency is:

Submit or [Cancel](#)

[Search](#)

[Advanced Search](#)

[Home](#)

[Artist A - Z](#)

[Profile](#)

[Bids](#)

[Projects](#)

[Shortlist](#)

[Contracts](#)

[Account](#)

[Contact](#)

[Location](#)

[Skills](#)

[Credits](#)

[Gallery](#)

[Diary](#)

[Qualifications](#)

[Reputation](#)

[Representation](#)

Julian Mann's Skills

Skill Cloud

FX Animator, Pipeline TD, Developer, Character Animator, Texture Artist, Matte Painter,
Rigger, Modeler, **Maya**, Photoshop, Z Brush, C++, Python, TCL, Shell Scripting, Linux, Physics,
Geometry, Fur

[Edit](#)

AJAX -

Only the skills for which the artist has positive rating are displayed. When the artist clicks the edit link, he is either taken to a new page "/users/13/skills_profile/edit" - or the contents of the page are replaced (using AJAX) with the contents of the edit page - i.e. a form containing a list of all possible skills.

Search

[Advanced Search](#)

[Home](#)

[Artist A - Z](#)

[Profile](#)

[Bids](#)

[Projects](#)

[Shortlist](#)

[Contracts](#)

[Account](#)

[Contact](#)

[Location](#)

[Skills](#)

[Credits](#)

[Gallery](#)

[Diary](#)

[Qualifications](#)

[Reputation](#)

[Representation](#)

Edit Julian Mann's Skills

Job Function

Compositor: <input type="text" value="Expert"/>	Char Animator: <input type="text" value="Novice"/>	FX Animator: <input type="text" value="Compet"/>	Rigger: <input type="text" value="Good"/>
Texture Artist: <input type="text" value="None"/>	Matchmover: <input type="text" value="None"/>	Matte Painter: <input type="text" value="None"/>	Lighting TD: <input type="text" value="None"/>
Crowd Sim TD: <input type="text" value="None"/>	Rotoscoper: <input type="text" value="None"/>	Render Wrangler: <input type="text" value="None"/>	Pipeline TD: <input type="text" value="None"/>
Sys Admin: <input type="text" value="None"/>	Developer: <input type="text" value="None"/>	Coordinator: <input type="text" value="None"/>	Producer: <input type="text" value="None"/>

Software Skills

Maya: <input type="text" value="None"/>	Houdini: <input type="text" value="None"/>	Lightwave: <input type="text" value="None"/>	Poser: <input type="text" value="None"/>
Photoshop: <input type="text" value="None"/>	Illustrator: <input type="text" value="None"/>	ZBrush: <input type="text" value="None"/>	Combustion: <input type="text" value="None"/>
Nuke: <input type="text" value="None"/>	Flame / Fire / Inferno: <input type="text" value="None"/>	Shake: <input type="text" value="None"/>	Cineon: <input type="text" value="None"/>
Telecine: <input type="text" value="None"/>	After Effects: <input type="text" value="None"/>	FCP: <input type="text" value="None"/>	Deep Paint: <input type="text" value="None"/>
Boujou: <input type="text" value="None"/>	PF Track: <input type="text" value="None"/>	Avid: <input type="text" value="None"/>	Renderman: <input type="text" value="None"/>

Programming Languages

C++: <input type="text" value="None"/>	Python: <input type="text" value="None"/>	C Shell: <input type="text" value="None"/>	Maya API: <input type="text" value="None"/>
Shake API: <input type="text" value="None"/>	Prman SL: <input type="text" value="None"/>	Mental Ray: <input type="text" value="None"/>	Houdini code: <input type="text" value="None"/>
Maya mel: <input type="text" value="None"/>	Cocoa: <input type="text" value="None"/>	C: <input type="text" value="None"/>	TCL: <input type="text" value="None"/>

Other Skills

Physics: <input type="text" value="None"/>	Geometry: <input type="text" value="None"/>	Drawing / Painting: <input type="text" value="None"/>	Photography: <input type="text" value="None"/>
Sculpting: <input type="text" value="None"/>	Needlepoint: <input type="text" value="None"/>	Fur: <input type="text" value="None"/>	Feathers: <input type="text" value="None"/>

Add more

Brick laying: [\[Delete\]](#)

Add

Save Changes or [Cancel](#)

[Search](#) [Advanced Search](#)

- [Home](#)
- [Artist A - Z](#)
- [Profile](#)
- [Bids](#)
- [Projects](#)
- [Shortlist](#)
- [Contracts](#)

- [Account](#)
- [Contact](#)
- [Location](#)
- [Skills](#)
- [Credits](#)
- [Gallery](#)
- [Diary](#)
- [Qualifications](#)
- [Reputation](#)
- [Representation](#)

Julian Mann's Credits

Projects and keywords

- [Edit](#) **Harry Potter and the Prisoner of Azkaban** - 2004 - Feature Film - head of research and development: MPC
Contribution: willow, branches, leaves, rain
- [Edit](#) **Troy** (2004) (head of research and development: MPC) (Feature Film) (sequence supervisor: MPC)
Contribution: Designed artificial life crowd software
- [Edit](#) **Harry Potter and the Chamber of Secrets** (2002) (Feature Film) (lead technical director: MPC)
Contribution: willow, branches, leaves, rain
- [Edit](#) **Below** (2002) (Feature Film) (texture programmer: Double Negative)
Contribution: I wrote a procedural rust texture system for a CG submarine
- [Edit](#) **Dragonfly** (2002) (Feature Film) (crowd simulation research and development: Double Negative)
Contribution: artificial life dragonfly swarms
- [Edit](#) **Harry Potter and the Sorcerer's Stone** (2001) (Feature Film) (technical director: MPC)
Contribution: ocean, surf, spray
- [Edit](#) **Captain Corelli's Mandolin** (2001) (Feature Film) (technical director)
Contribution: stukka, camouflage, decal
- [Edit](#) **Enemy at the Gates** (2001) (Feature Film) (technical director: Double Negative)
Contribution: stukka, camouflage, decal
- [Edit](#) **Nutty Professor II: The Klumps** (2000) (Feature Film) (visual effects supervisor: double negative)
Contribution: gloop, fluids

Edit Credit

Project: **Project Type:** **Year:**

Credit:

Enter a full description or keywords.

Credit:

[Save Changes](#) or [Cancel](#)

- [Edit](#) **"The 10th Kingdom"** (2000) (TV Series) (digital effects artist)
Contribution: vines
- [Edit](#) **Pitch Black** (2000) (Feature Film) (cg supervisor: computer animation: AX) (cg supervisor: computer animation: AX) (cg supervisor: computer animation: AX)
Contribution: monster, flock, rigging
- [Edit](#) **The Mask of Zorro** (1998) (Feature Film) (computer graphics designer: Digital Film)
Contribution: boat, sea
- [Edit](#) **The Borrowers** (1997) (Feature Film) (research and development: MPC) (uncredited)
Contribution: motion capture, pod, kitchen
- [Edit](#) **The English Patient** (1996) (Feature Film) (computer generated designer: Digital Film)
Contribution: fire, smoke, desert, parachute

Each entry in the div has "edit / delete" links that appear when the mouse hovers over the entry. Also there is an "add" link below. Ajax is used to replace each entry individually with a small form to edit that entry. This is how basecamp handles Todo List editing.

New Credit

Project: **Project Type:** **Year:**

Credit:

Enter a full description or keywords.

Credit:

[Submit](#) or [Cancel](#)

[\[+\] Add another Credit](#)

Scrape IMDB to add credits

To save time, press the scrape button and we will try to get your credit entries from the internet Movie Database. If successful you will be shown the list, then you can choose which credits to import.

IMDB URL: [Scrape](#)

Search

[Advanced Search](#)

[Home](#)

[Artist A - Z](#)

[Profile](#)

[Bids](#)

[Projects](#)

[Shortlist](#)

[Contracts](#)

[Account](#)

[Contact](#)

[Location](#)

[Skills](#)

[Credits](#)

[Gallery](#)

[Diary](#)

[Qualifications](#)

[Reputation](#)

[Representation](#)

Julian Mann's Media Gallery

Movies and Images

[Edit](#) 



Showreel_2006

00:21 - I didn't do anything on this show
01:14 - tree, leaves, debris - fx animation.

[Edit](#) 

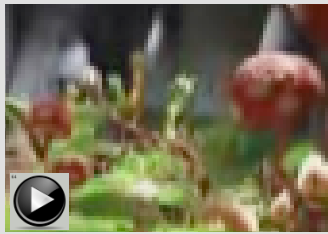

R&D Clips

grass shaders. fluid dynamics.

AJAX - Each entry in the div has "edit / delete" links that appear when the mouse hovers over the entry. Also there is an "add" link below. Ajax is used to replace each entry individually with a small form to edit that entry. This is how basecamp handles Todo List editing.

Edit Media

Upload a movie or image and describe your contribution or simply enter keywords

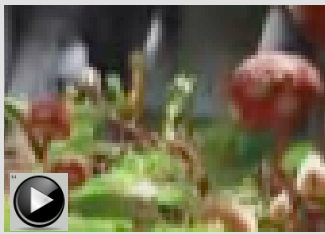

File:

Browse

Upload

Title:

Description:

Save Changes

or [Cancel](#)

[Edit](#) 

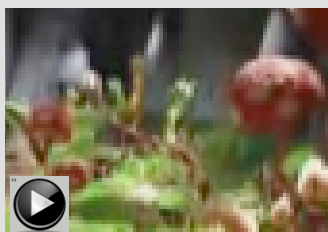

Cloverfield Concept image

Software used - Photoshop, Illustrator - 3 days work

New Media

Upload a movie or image and describe your contribution

No Image

File:

Browse

Upload

Title:

Description:

Submit

or [Cancel](#)

[\[+\] Add another Media File](#)

Search

[Advanced Search](#)

[Home](#)

[Artist A - Z](#)

[Profile](#)

[Bids](#)

[Projects](#)

[Shortlist](#)

[Contracts](#)

[Account](#)

[Contact](#)

[Location](#)

[Skills](#)

[Credits](#)

[Gallery](#)

[Diary](#)

[Qualifications](#)

[Reputation](#)

[Representation](#)

Julian Mann's Availability

Diary

To set your availability, drag over dates in the calendar and press one of the buttons to the right

<< < July 2007 > >>

June 2007						
S	M	T	W	Th	F	Sa
					1	2
3	4	5	6	7	8	9
10	11	12	13	14	15	16
17	18	19	20	21	22	23
24	25	26	27	28	29	30

July 2007						
S	M	T	W	Th	F	Sa
1	2	3	4	5	6	7
8	9	10	11	12	13	14
15	16	17	18	19	20	21
22	23	24	25	26	27	28
29	30	31				

August 2007						
S	M	T	W	Th	F	Sa
			1	2	3	4
5	6	7	8	9	10	11
12	13	14	15	16	17	18
19	20	21	22	23	24	25
26	27	28	29	30	31	

Employers can search to match your availability

Make Me Available

Unavailable Label:

Make Me Unavailable

Search

[Advanced Search](#)

[Home](#)

[Artist A - Z](#)

[Profile](#)

[Bids](#)

[Projects](#)

[Shortlist](#)

[Contracts](#)

[Account](#)

[Contact](#)

[Location](#)

[Skills](#)

[Credits](#)

[Gallery](#)

[Diary](#)

[Qualifications](#)

[Reputation](#)

[Representation](#)

Julian Mann's Qualifications

[Edit](#) 

Mathematics A Level, Ravenswood School 1980

[Edit](#) 

Computer Graphics BA, Bournemouth University 1985

[Edit](#) 

Physics PhD, Massachuset Institute of Technology 1986

Editing

Subject:

Degree:

Year:

School:

Mathematics

A Level

1980

Ravenswood School

Save Changes

or [Cancel](#)

Add Qualification

AJAX - Each entry in the div has "edit / delete" links that **appear when the mouse hovers over the entry**. Also there is an "add" link below. Ajax is used to replace each entry individually with a small form to edit that entry. This is how basecamp handles Todo List editing.

Do we need a "grade" field?

[Search](#) [Advanced Search](#)

[Home](#) [Artist A - Z](#) [Profile](#) [Bids](#) [Projects](#) [Shortlist](#) [Contracts](#)

[Account](#) [Contact](#) [Location](#) [Skills](#) [Credits](#) [Gallery](#) [Diary](#) [Qualifications](#) [Reputation](#) [Representation](#)

Endorsements for Fred Bird

[See artists Fred has recommended](#)
[Write a Recommendation for Fred](#)

1 2 3 4 Next

I worked with Fred for 8 months at ILM and a year on a short film project. He taught me everything I know. He's a pleasure to be around and a true pro. Whatever you are thinking of paying him, he's worth double at least. He saved at least 3 major facilities from ruin. He's brilliant, cool swarve, a hit with the ladies etc.

[Jason MacDonald](#) - colleague - 10 July 2007 - [See other artists endorsed by Jason](#)



Fred is cool to work with, always on time, very creative !

[Andy Middleton](#) - colleague - 11 July 2007 - [See other artists endorsed by Andy](#)



Fred is thorough, conscientious and consistently inventive. He never backs away from a daunting challenge and has a high degree of commitment to producing high calibre work. I would easily recommend him as a dedicated and valued worker.

[Steve Macpherson](#) colleague - 11 July 2007 - [See other artists endorsed by Steve](#)



*Fred worked well on this project, always on time, very creative, etc.
sdjfhshdfgsjdghfjhdsf*

*We will hire him again. What a star
djfhjhkdsg 'lsdkf ;kjfs'sd;f k'dskfs' ' fd*

[Elie Jamaa](#) - friend - 10 July 2007 - [See other artists endorsed by Elie](#)



Fred is cool to work with, always on time, very creative !

[Andy Serkis](#) - friend - 11 July 2007 -

Don't show "see other endorsements" if there are no others



Fred is thorough, conscientious and consistently inventive. He never backs away from a daunting challenge and has a high degree of commitment to producing high calibre work. I would easily recommend him as a dedicated and valued worker.

[Simon Brown](#) - colleague - 11 July 2007



employers don't have a reputation profile (maybe they should)

Fred is thorough, conscientious and consistently inventive. He never backs away from a daunting challenge and has a high degree of commitment to producing high calibre work. I would easily recommend him as a dedicated and valued worker.

[Julian Mann](#) colleague - 11 July 2007 - [See other artists endorsed by you](#)



I worked with Fred for 8 months at ILM and a year on a short film project. He taught me everything I know. He's a pleasure to be around and a true pro. Whatever you are thinking of paying him, he's worth double at least. He saved at least 3 major facilities from ruin. He's brilliant, cool swarve, a hit with the ladies etc.

[Jonny Depp](#) - employer - 10 July 2007 - [See other artists endorsed by Jonny](#)



1 2 3 4 Next

When a user writes an endorsement for an artist, it is sent to the artist as an email first. The artist accepts or rejects the recommendation. (because maybe someone with a grudge writes "Fred is a wanker") - we cant just allow that to go through.

Any user can write a endorsement for an artist

Search

[Advanced Search](#)

[Home](#)

[Artist A - Z](#)

[Profile](#)

[Bids](#)

[Projects](#)

[Shortlist](#)

[Contracts](#)

[Reputation](#)

Endorsements for Julian Bird

[See artists Julian has recommended](#)

[Write an Endorsement for Julian](#)

1 2 3 4 Next

I worked with Julian for 8 months at ILM and a year on a short film project. He taught me everything I know. He's a pleasure to be around and a true pro. Whatever you are thinking of paying him, he's worth double at least. He saved at least 3 major facilities from ruin. He's brilliant, cool swarve, a hit with the ladies etc.

[Jason MacDonald](#) - colleague - 10 July 2007 - [See other artists endorsed by Jason](#)

Julian is cool to work with, always on time, very creative !

[Fred - \(YOU\)](#) colleague - 11 July 2007 - [See other artists endorsed by you](#)

Edit



Julian is thorough, conscientious and consistently inventive. He never backs away from a daunting challenge and has a high degree of commitment to producing high calibre work. I would easily recommend him as a dedicated and valued worker.

[Steve Macpherson](#) colleague - 11 July 2007 - [See other artists endorsed by Steve](#)

Julian worked well on this project, always on time, very creative, etc.

sdjfhshdfgsjdghfjhdsf

We will hire him again. What a star

djfhjhkdfsg 'lsdkf ;kjfds'sd;f k'dskfs' ' fd

[Elie Jamaa](#) - friend - 10 July 2007 - [See other artists endorsed by Elie](#)

Julian is cool to work with, always on time, very creative !

[Andy Serkis](#) - friend - 11 July 2007 -

Don't show "see other endorsements" if there are no others

Julian is thorough, conscientious and consistently inventive. He never backs away from a daunting challenge and has a high degree of commitment to producing high calibre work. I would easily recommend him as a dedicated and valued worker.

[Simon Brown](#) - colleague - 11 July 2007

employers don't have a reputation profile

Julian is thorough, conscientious and consistently inventive. He never backs away from a daunting challenge and has a high degree of commitment to producing high calibre work. I would easily recommend him as a dedicated and valued worker.

[Julian Mann](#) colleague - 11 July 2007 - [See other artists endorsed by you](#)

I worked with Julian for 8 months at ILM and a year on a short film project. He taught me everything I know. He's a pleasure to be around and a true pro. Whatever you are thinking of paying him, he's worth double at least. He saved at least 3 major facilities from ruin. He's brilliant, cool swarve, a hit with the ladies etc.

[Jonny Depp](#) - employer - 10 July 2007 - [See other artists endorsed by Jonny](#)

1 2 3 4 Next

When a user writes an endorsement for an artist, it is sent to the artist **as an email first**. The artist accepts or rejects the endorsement. (because maybe someone with a grudge writes "Julian is a wanker") - we cant just allow that to go through.

Any user can write a endorsement for an artist

Search

[Advanced Search](#)

[Home](#)

[Artist A - Z](#)

[My Profile](#)

[Bids](#)

[Projects](#)

[Shortlist](#)

[Contracts](#)

[Account](#)

[Contact](#)

[Location](#)

[Skills](#)

[Credits](#)

[Gallery](#)

[Diary](#)

[Qualifications](#)

[Reputation](#)

[Representation](#)

Julian Mann's Representation

Company Representation

I a representative of : [The Moving Picture Company](#) in London, UK

My Job Title is: Assistant Recruitment Coordinator

I am not the primary representative.

[Edit](#)

[Delete](#)

Change Representation

If you choose to represent an existing organization, an email will be sent to the primary representative of that organization requesting authorization. You will not be able to manage recruitment on behalf of that organization until the authorization is sent.

I will represent an existing organization:

I will be the primary representative for a new organization:

[Submit](#)

or [Cancel](#)

AJAX - When the user clicks "Edit", The static div should be replaced with the "change" div.

The primary rep cannot change the company he represents without first deactivating / deleting the company, or transferring primary representation rights to a secondary representative of that company. If he deactivates the company, there must be no open bids, projects or positions. If there never were any finalized bids for that company, it may be deleted.

[Search](#) [Advanced Search](#)

[Home](#)

[Artist A-Z](#)

Julian Mann

"Add to Shortlist" pops up a small window (or inserts a div) that simply allows the current user to make a note about this artist. When a note is made the artist is added to shortlist. Artists who already have notes (by current user) will have "Edit Note" link and delete note button instead.

Julian Mann

[Add to Shortlist](#)

[Place a bid](#)

Location



I am based in UK
I Speak English and French
I can commute to London, UK
I am not prepared to relocate
I can work remotely and I have computers running Mac OSX and Windows
My preferred currency is Euro

Diary

<<< < July > >>> 2007

June 2007						
S	M	T	W	Th	F	Sa
					1	2
3	4	5	6	7	8	9
10	11	12	13	14	15	16
17	18	19	20	21	22	23
24	25	26	27	28	29	30

July 2007						
S	M	T	W	Th	F	Sa
1	2	3	4	5	6	7
8	9	10	11	12	13	14
15	16	17	18	19	20	21
22	23	24	25	26	27	28
29	30	31				

August 2007						
S	M	T	W	Th	F	Sa
		1	2	3	4	
5	6	7	8	9	10	11
12	13	14	15	16	17	18
19	20	21	22	23	24	25
26	27	28	29	30	31	

Skills

FX Animator, Pipeline TD, Developer, Character Animator, Texture Artist, Matte Painter, Rigger, Modeler, Maya, Photoshop, Z Brush, C++, Python, TCL, Shell Scripting, Linux, Physics, Geometry, Fur

00:21 - chocolate waterfall - animation - rendering.
01:14 - tree, leaves, debris - fx animation.

Media Gallery

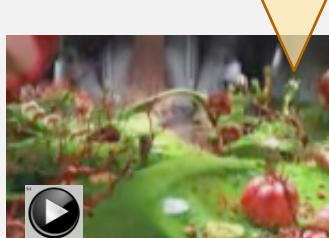

Showreel_2006

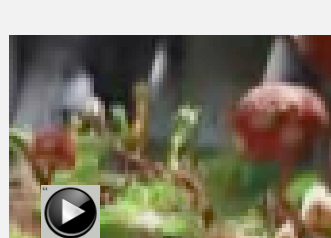

movie_2

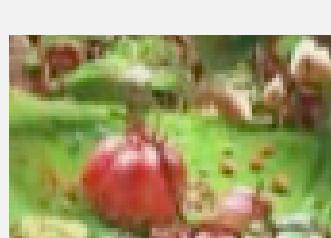
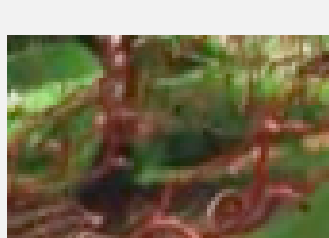

image1



myImage2

Credits

Harry Potter and the Prisoner of Azkaban - 2004 - Feature Film - head of research and development: MPC
Contribution: willow, branches, leaves, rain

Troy (2004) (head of research and development: MPC) (Feature Film) (sequence supervisor: MPC)
Contribution: I Created the artificial life crowd software

Harry Potter and the Chamber of Secrets (2002) (Feature Film) (lead technical director: MPC)
Contribution: willow, branches, leaves, rain

Below (2002) (Feature Film) (texture programmer: Double Negative)
Contribution: I wrote a procedural rust texture system that was used for the submarine

Dragonfly (2002) (Feature Film) (crowd simulation research and development: Double Negative)
Contribution: artificial life dragonfly swarms

Harry Potter and the Sorcerer's Stone (2001) (Feature Film) (technical director: MPC)
Contribution: ocean, surf, spray

Captain Corelli's Mandolin (2001) (Feature Film) (technical director)
Contribution: stukka, camouflage, decal

Enemy at the Gates (2001) (Feature Film) (technical director: Double Negative)
Contribution: stukka, camouflage, decal

Nutty Professor II: The Klumps (2000) (Feature Film) (visual effects supervisor: double negative)
Contribution: gloop, fluids

"Randall & Hopkirk (Deceased)" (2000) (TV Series) (digital effects artist)
Contribution: I recreated a 3d village from arial photographs and dressed it with paint fx flora. Then I animated a tornado that sucked up the whole shebang while causing landscape to form a whirlpool, which everything subsequently disappeared into.

"The 10th Kingdom" (2000) (TV Series) (digital effects artist)
Contribution: vines

Pitch Black (2000) (Feature Film) (cg supervisor: computer animation & modeling)
Contribution: monster, flock, rigging

The Mask of Zorro (1998) (Feature Film) (computer graphics designer: Digital Film)
Contribution: boat, sea

The Borrowers (1997) (Feature Film) (research and development: MPC) (uncredited)
Contribution: motion capture, pod, kitchen

The English Patient (1996) (Feature Film) (computer generated designer: Digital Film)
Contribution: fire, smoke, desert, parachute

Contract history is simply a list of finalized bids for this artist. Only contracts previously agreed on vfxtalent are listed here.

An endorsement from a representative who hired the artist can be attached to a bid. It will also appear in the endorsements list of course

Contract History

Narnia 2 - MPC - VFX Supervisor - Feature Film - 23-Jul-2006 to Current - [See other crew](#)

Troy - MPC - sequence supervisor - Feature Film - 20-Jun-2004 to 17-Feb-2007 - [See other crew](#)
Feedback: Julian worked well on this project, always on time, very creative. We will hire him again. What a star. Wikipedia, and eBay as examples and muses whether their models could be applied more widely.

Flyboys - DNEG - Animator - Feature Film - 23-Jul-2000 to 18-May-2003 - [See other crew](#)
Feedback: Julian is great endorsement. The ways in which reputations spread can affect their ability to influence behavior, and it is especially interesting to consider situations where people exercise some control over the spread of their own reputations, a situation that is common on the Internet.

Lord of the Rings - WETA - pipeline programmer - Feature Film - 20-Jun-2004 to 17-Feb-2007 - [See other crew](#)
Feedback: Julian is thorough, conscientious and consistently inventive. He never backs away from a daunting challenge and has a high degree of commitment to producing high calibre work. I would easily recommend him as a dedicated and valued worker.

Reputation

[See all endorsements for Julian](#)

[See 15 artists endorsed by Julian](#)

[Endorse Julian](#)

[Request endorsement from Julian](#)

I worked with Julian for 8 months at ILM and a year on a short film project. He taught me everything I know. He's a pleasure to be around and a true pro. Whatever you are thinking of paying him, he's worth double at least. He saved at least 3 major facilities from ruin. He's brilliant, cool swarve, a hit with the ladies etc.
[Jason MacDonald - colleague - 10 July 2007 - See other artists endorsed by Jason](#)

Julian is cool to work with, always on time, very !
[Andy Middleton - colleague - 11 July 2007 - See other artists endorsed by Andy](#)

Julian is thorough, inventive. He never backs away from a daunting challenge and has a high degree of commitment to producing high calibre work. I would easily recommend him as a dedicated and valued worker. Can I have my tenner now.
[Steve Macpherson colleague - 11 July 2007 - See other artists endorsed by Steve](#)

Julian is cool to work with, always on time, very creative - with his CV anyway!
[Andy Serkis - friend - 11 July 2007 -](#)

Julian is thorough and consistently inventive. He never backs away from a challenge and has a high degree of commitment to producing high calibre work. I would easily recommend him as a dedicated and valued worker. Can I have my tenner now.
[Simon Brown - colleague - 11 July 2007](#)

Qualifications

Mathematics A Level, Ravenswood School 1980
Computer Graphics BA, Bournemouth University 1985
Physics PhD, Massachuset Institute of Technology 1986

[Add to Shortlist](#)

[Place a bid](#)

[Search](#) [Advanced Search](#)

[Home](#)

[Artist A - Z](#)

Shortlist pops up a small window (or inserts a div) that simply allows the current user to make a note about the artist and optionally "add to shortlist" using a checkbox. Artists who already have notes (by current user) will have "Edit Note" link - and will have a floating info bubble appear when mouse rolls over their name (or icon)

<< [PREV](#) Displaying: 11 to 20 out of 36 results [NEXT](#) >>



[Shah Khan](#) Ahmedabad, India
Skills: Composer, Programmer, Shake, Maya, Python, Photography, On-set supervision
Contracts: Troy (film) july 02 - Aug 06, 10kBC (film) Nov 06 - Jan 07, **Narnia**
[See Showreel](#) | [Shortlist](#) | [Bid Now](#) | [Recommend](#) | [Request Recommendation](#)



[Julian Mann](#) London, UK
Skills: FX Animator, Programmer, Maya, Maya API, C++, Python, Anatomy, Geometry
Contracts: Troy (film) july 02 - Aug 06, Codename Title (film) Nov 06 - Jan 07
[See Showreel](#) | [Edit Note](#) | [Bid Now](#) | [Recommend](#) | [Request Recommendation](#)



[Derek wentworth](#) Brisbane, AU
Skills: Composer, Animator, VFX Sup, Shake, Maya, Photography, On-set supervision ...
Recent: Troy (film) july 02 - Aug 06, 10kBC (film) Nov 06 - Jan 07, **Wonder Woman since Feb 07**
[See Showreel](#) | [Shortlist](#) | [Bid Now](#) | [Recommend](#) | [Request Recommendation](#)



[Richard Bain](#) Wellington, NZ
Skills: Composer, Programmer, Shake, Maya, Python, Photography, On-set supervision
Contracts: Troy (film) july 02 - Aug 06, 10kBC (film) Nov 06 - Jan 07, **Offline since May 06**
[See Showreel](#) | [Edit Note](#) | [Bid Now](#) | [Recommend](#) | [Request Recommendation](#)



[Olivier Junquet](#) Paris, FR
Skills: Composer, Programmer, Shake, Maya, Python, Photography, On-set supervision
Contracts: Troy (film) july 02 - Aug 06, 10kBC (film) Nov 06 - Jan 07, **Offline since June 05**
[See Showreel](#) | [Shortlist](#) | [Bid Now](#) | [Recommend](#) | [Request Recommendation](#)

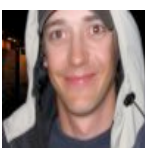

[Elie Jamaa](#) Brisbane, AU
Skills: Composer, Programmer, Shake, Maya, Python, Photography, Arial Photography
Contracts: Troy (film) july 02 - Aug 06, 10kBC (film) Nov 06 - Jan 07, **Offline since June 05**
[See Showreel](#) | [Edit Note](#) | [Bid Now](#) | [Recommend](#) | [Request Recommendation](#)

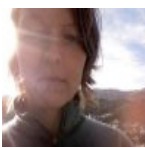

[Katherine Suminska](#) London, UK
Skills: FX Animator, Programmer, Maya, Maya API, C++, Python, Anatomy, Geometry, Fluids ...
Contracts: Troy (film) july 02 - Aug 06, 10kBC (film) Nov 06 - Jan 07, **Offline since June 05**
[See Showreel](#) | [Shortlist](#) | [Bid Now](#) | [Recommend](#) | [Request Recommendation](#)



[Jessica Braun](#) Berlin, DE
Skills: FX Animator, Programmer, Maya, Maya API, C++, Python, Anatomy, Geometry, Crowds ...
Contracts: Troy (film) july 02 - Aug 06, 10kBC (film) Nov 06 - Jan 07, **Offline since June 05**
[See Showreel](#) | [Shortlist](#) | [Bid Now](#) | [Recommend](#) | [Request Recommendation](#)



[Ian Ward](#) London, UK
Skills: FX Animator, Programmer, Maya, Maya API, C++, Python, Anatomy, Geometry, Physics ...
Contracts: Troy (film) july 02 - Aug 06, 10kBC (film) Nov 06 - Jan 07, **Offline since June 05**
[See Showreel](#) | [Shortlist](#) | [Bid Now](#) | [Recommend](#) | [Request Recommendation](#)



[Hannah Walker](#) Bristol, UK
Skills: FX Animator, Programmer, Maya, Maya API, C++, Python, Anatomy, Geometry, Physics ...
Contracts: Troy (film) july 02 - Aug 06, 10kBC (film) Nov 06 - Jan 07, **Offline since June 05**
[See Showreel](#) | [Shortlist](#) | [Bid Now](#) | [Recommend](#) | [Request Recommendation](#)

```
Search Parameters: {:simple=>"maya explosion david"}

Search Parameters: {
  :advanced={
    :name="david",
    :availability=["27/05/08", "1/12/08", "50%"],
    :skills={
      :list=["maya", "anatomy"],
      :op="ANY"
    },
    :credits={
      :project="potter",
      :keywords=["explosion", "rain", "night"],
      :op="ANY"
    },
    :location={
      :commute=["mumbai", "india"],
      :remote=["yes", "mac"]
    }
  }
}
```

if visitor is an artist, he sees following links:
[See Showreel](#)
[Recommend](#)
[Request Recommendation](#)

if visitor is an employer, he sees following links:
[See Showreel](#)
[Shortlist](#)
[Bid Now](#)
[Recommend](#)

if visitor is the admin, he also sees employers

Name = links to full profile ...
Matched terms (**bold** and in context) - (*not shown here yet*)
Skills (Highest proficiency first)
Contracts - last 2 or 3 projects hired through vfxtalent.
The total value of an artist's past contracts (signed through vfxtalent) has an effect on his relevance in search results

Search

[Advanced Search](#)

[Home](#)

[Artist A - Z](#)

[Profile](#)

[Bids](#)

[Projects](#)

[Shortlist](#)

[Contracts](#)

Endorsements

Artists endorsed by Fred Bird

[See endorsements for Fred](#)

1 2 3 4 Next

[Jason MacDonald](#) - colleague

I worked with Jason for 8 months at ILM and a year on a short film project. He taught me everything I know. He's a pleasure to be around and a true pro. Whatever you are thinking of paying him, he's worth double at least. He saved at least 3 major facilities from ruin. He's brilliant, cool swarve, a hit with the ladies etc.

10 July 2007 - [See other endorsements for Jason - Recommend Jason](#)

[Andy Middleton](#) - colleague

Andy is cool to work with, always on time, very creative !

11 July 2007 - [See other endorsements for Andy - Recommend Andy](#)

[Steve Macpherson](#) - colleague

I worked with Steve for 8 months at ILM and a year on a short film project. He taught me everything I know. He's a pleasure to be around and a true pro. Whatever you are thinking of paying him, he's worth double at least. He saved at least 3 major facilities from ruin. He's brilliant, cool swarve, a hit with the ladies etc.

10 July 2007 - [See other endorsements for Steve - Recommend Steve](#)

[Jason MacDonald](#) - colleague

I worked with Jason for 8 months at ILM and a year on a short film project. He taught me everything I know. He's a pleasure to be around and a true pro. Whatever you are thinking of paying him, he's worth double at least. He saved at least 3 major facilities from ruin. He's brilliant, cool swarve, a hit with the ladies etc.

10 July 2007 - [See other endorsements for Jason - Recommend Jason](#)

[Andy Middleton](#) - colleague

Andy is cool to work with, always on time, very creative !

11 July 2007 - [See other endorsements for Andy - Recommend Andy](#)

[Steve Jones](#) - colleague

I worked with Steve for 8 months at ILM and a year on a short film project. He taught me everything I know. He's a pleasure to be around and a true pro. Whatever you are thinking of paying him, he's worth double at least. He saved at least 3 major facilities from ruin. He's brilliant, cool swarve, a hit with the ladies etc.

10 July 2007 - [Recommend Steve](#)

[Jason MacDonald](#) - colleague

I worked with Jason for 8 months at ILM and a year on a short film project. He taught me everything I know. He's a pleasure to be around and a true pro. Whatever you are thinking of paying him, he's worth double at least. He saved at least 3 major facilities from ruin. He's brilliant, cool swarve, a hit with the ladies etc.

10 July 2007 - [See other endorsements for Jason - Recommend Jason](#)

1 2 3 4 Next

[Search](#)

[Advanced Search](#)

[Home](#)

[Artist A - Z](#)

[Profile](#)

[Bids](#)

[Projects](#)

[Shortlist](#)

[Contracts](#)

[Organization](#)

The Moving Picture Company



The Moving Picture Company Ltd.
127 Wardour Street,
London, UK
W1V 4NL
0207 434 3100

200 - 500 Employees
Post Production & Visual Effects
www.moving-picture.com

Default Currency: GBP

About Us: MPC provides the very best in digital visual effects and post production for the international advertising, television and feature film industries. We use and develop the best tools and techniques for the job and deliver the most creative work on time and to budget.

[Edit](#)

Primary Representative: Matthew Sagar



Job Title: HR Manager
Email: matt-s@moving-picture.com
Phone: 0207 434 1619
Skype: matt.sagar
MSN: matts@hotmail.co.uk

Representative: Kate Tabbard



Job Title: Recruitment Coordinator
Email: kate-t@moving-picture.com
Phone: 0207 434 1622
Skype: kate.tabbard
MSN: katet@hotmail.co.uk

Representative: Emma McConigle



Job Title: Recruitment Coordinator
Email: emma-m@moving-picture.com
Phone: 0207 434 1623
Skype: emma.mac
MSN: emmam@hotmail.co.uk

Search

[Advanced Search](#)

[Home](#)

[Artist A - Z](#)

[Profile](#)

[Bids](#)

[Projects](#)

[Shortlist](#)

[Contracts](#)

Organization

Edit The Moving Picture Company

Company Name:

Address 1:

Address 2:

Town:

State / Region:

Post Code:

Country:

Phone:

Website:

Organization size:

Preferred Currency:

About Us:



You can upload a small photo (GIF, JPG, or PNG), which will be resized to max 100 pixels high.

Browse

Upload Now

Representatives

Matt Sagar: (1) Primary Representative

Kate Tabbard: Recruitment Coordinator

Emma McGonigle : Recruitment Coordinator

Submit

or [Cancel](#)

Search

[Advanced Search](#)

[Home](#)

[Artist A - Z](#)

[Profile](#)

[Bids](#)

[Projects](#)

[Shortlist](#)

[Contracts](#)

[New Project](#)

Project

Project Long Name:

Project Short Name:

Project Type:

Start Date:

End Date:

Location:

Description:

Some descriptive notes about the project go here.

Positions

Position:

Number of Vacancies:

Start Date:

End Date:

Responsibilities:

Give an outline of the job responsibilities here, like you would in a job ad.

[Remove](#)

Position:

Number of Vacancies:

Start Date:

End Date:

Responsibilities:

Give an outline of the job responsibilities here, like you would in a job ad.

[Remove](#)

Position:

Number of Vacancies:

Start Date:

End Date:

Responsibilities:

Give an outline of the job responsibilities here, like you would in a job ad.

[Remove](#)

[\[+\] Add Another Position](#)

Submit

or [Cancel](#)

[Search](#)

[Advanced Search](#)

[Home](#)

[Artist A - Z](#)

[Profile](#)

[Bids](#)

[Projects](#)

[Shortlist](#)

[Contracts](#)

[New Bid](#)

Bid to Artist: from Kate Tabbard representing The Moving Picture Company:

Artist: [Ben Shepherd](#)

Position / Project:

Contract:

[View](#)

Amount:

Currency:

Frequency:

Start Date:

End Date:

Hi Ben,
Kindly consider my bid for your services as Texture Artist on Charlie Chocolate.
Thanks.
Kate

I have read and agree to the vfxTalent [Terms and Conditions](#):

[Submit](#)

or [Cancel](#)

[Open interview with artist:](#)

[Search](#) [Advanced Search](#)

[Home](#)

[Artist A - Z](#)

[Profile](#)

[Bids](#)

[Projects](#)

[Shortlist](#)

[Contracts](#)

[Show Bid](#)

NOTE: This is the employers view of the bid
In the artists view there will be no Edit button in the Bid Details div.
And of course the status div will contain different actions for an artist.

Bid 166571 to [Steve Moncur](#) from [The Moving Picture Company](#)

Bid Status

Status: Accepted

[Finalize](#)

[Retract](#)

Bid Details

Representative: [Kate Tabbard](#).

Position: [Texture Artist](#) - Project: [Flushed Away](#)

Current bid value: 250 Pounds per Calendar Month for the period 13 September - 20 October 2008

Contract: [standard UK Resident](#)

AJAX -
When the user clicks "edit" in Bid details div, the div is replaced by the "Edit Bid Details" div

[Edit](#)

Edit Bid Details

Representative :

Position / Project :

Amount:

Currency:

Frequency:

Start Date:

End Date:

Contract: [View](#)

[Submit](#)

or [Cancel](#)

Communication Log

09 Sept 15:31 - New Bid Notification - Kate Tabbard (The Moving Picture Company)

- * Artist: Steve Moncur
- * Representative: Kate Tabbard
- * Organization: The Moving Picture Company
- * Project: Harry Potter 1
- * Position: Texture Artist
- * Bid amount: 123.00 US Dollar Per Day
- * Status: Open
- * Start date: 2006-11-19
- * End date: 2007-11-19

Messages in the communications log are from the artist, or from the employer's representative who owns the bid at the time the message was created. Messages with a title containing the word "Notification" are messages that were automatically generated by the system.

There is a string field called "rep_name" in the message table. This holds the name of the rep at the time the bid was created. (NOT Live record association)

All messages are echoed to both party's email. The subject in the email is "Bid 166571 Activity" and sender is "VFXTalent" - In this way the email clients wil contain full bid history in 1 thread.

29 Oct 03:11 - Message from Bidder - Kate Tabbard (The Moving Picture Company)

Hi Steve, Kindly consider my bid for your services.

Kate

29 Oct 06:11 - Message from Artist - Steve Moncur

Kate,
Looks like an exciting project, but the price is way too low and in dollars. I need at least 240 GBP per day

29 Oct 08:11 - Bid Changed Notification - Kate Tabbard (The Moving Picture Company)

- * Bid amount changed from 123.00 Dollars Per Day to 250 Pounds Per Day

29 Oct 12:15 - Bid Declined Notification - Steve Moncur

Dear Kate

Thank you very much for offering me the position of Texture artist for the project Flushed Away. Regrettably I have to inform you that I have had a bid finalized by another organization for dates that coincide with your bid. Therefore, I must decline your offer. I do appreciate the courtesy extended to me by The Moving Picture Company, and I wish you well in your endeavors to fill this position.

Best regards,

Note, this message is automatically generated by the system. There will be other similar messages generated from other bid events.

Steve

Reply....

[Send](#) or [Cancel](#)

[Search](#)[Advanced Search](#)[Home](#)[Artist A - Z](#)[Profile](#)[Bids](#)[Projects](#)[Shortlist](#)[Contracts](#)**Library >**

DEFAULT

[Standard 5wks Holiday](#)[Another Contract](#)[Sopecial Contract](#)**Live Bid Contracts >**[James_Dong](#)[Andy_Rawling](#)[Fred_Chapman](#)[Dave_Spark](#)[Andy_Middleton](#)**Finalized Contracts >**[James_Dong](#)[Andy_Rawling](#)[Fred_Chapman](#)[Dave_Spark](#)[Andy_Middleton](#)

This is the default library contract and cannot be edited.
You may create and edit a duplicate

[Duplicate](#)

This is the employers view of the default library contract.

Library Contract: default

THIS EMPLOYMENT AGREEMENT is made the **[BID_ACCEPTED_DATE]**

BETWEEN:

- (1) **[EMPLOYER_COMPANY_NAME]**
of **[EMPLOYER_COMPANY_ADDRESS]** ("the Employer");
- (2) and **[ARTIST_NAME]** of **[ARTIST_ADDRESS]** ("You").

This Agreement sets out the contractual terms of your employment with the Employer as follows:

1. Date of employment

- 1.1 It is anticipated that your employment will begin on **[EMPLOYMENT_START_DATE]** and will continue until **[EMPLOYMENT_END_DATE]** and is subject to a standard one-month probationary period. Your employment will be reviewed shortly before your contract end date with a view to renewal but this cannot be guaranteed.

2. YOUR duties

- 2.1 You are employed as a Freelance Visual Effects Artist. You will be informed as to your duties by The Managing Director. Your duties may be varied from time to time provided they are appropriate to your knowledge and status.
- 2.2 During your employment you will spend the whole of your time, attention and ability carrying out your duties with due care and attention.

3. Standard of work

You are required to reach a standard of work appropriate to your Position in the company. These standards will be set out by the Employer at the beginning of your employment.

4. Working time and place

- 4.1 Your hours will be 9.00am to 6pm (Monday to Friday)
- 4.2 You may be required to work outside these hours should it be necessary in order to complete the tasks you have been allocated. Regulation 4(1) of the Working Time Regulations 1998 (the "WTR") provides that an employee's average working time, including overtime, should not exceed 48 hours each week unless the employee agrees otherwise. In accordance with Regulation 5, you agree that Regulation 4(1) of the WTR will not apply to your employment. You or the Employer may at any time give three months written notice to withdraw this opt out.
- 4.3 Your principal places of work shall be **[EMPLOYER_COMPANY_ADDRESS]** or such other location as the Employer may from time to time determine. The Employer will give 1 week's notice of any permanent change of location.

5. Salary

- 5.1 Your salary of **[BID_CURRENCY]** **[BID_AMOUNT]** per **[BID_AMOUNT_FREQUENCY]**, will be paid monthly in arrears direct into your bank account. Salary shall be paid less all deductions required by law, including deduction of income tax and national insurance.
- 5.2 There is no pension payable in respect of the employment. Provided that you are eligible, the Employer will provide you with details of its designated stakeholder pension scheme ("SPS") to which you may elect to have access. The Employer will not make any contribution to the SPS on your behalf. The Employer makes no recommendations in respect of the SPS, nor does it make any representation or warranty as to its suitability for you.

6.etc

[Search](#)

[Advanced Search](#)

[Home](#)

[Artist A - Z](#)

[Profile](#)

[Bids](#)

[Projects](#)

[Shortlist](#)

[Contracts](#)

Library >

DEFAULT

Standard 5wks Holiday

[Another Contract](#)

[Sopecial Contract](#)

Live Bids >

[James_Dong](#)

[Andy_Rawling](#)

[Fred_Chapman](#)

[Dave_Spark](#)

[Andy_Middleton](#)

Finalized >

[James_Dong](#)

[Andy_Rawling](#)

[Fred_Chapman](#)

[Dave_Spark](#)

[Andy_Middleton](#)

This is a library contract.
You may create edit it or create duplicate

[Edit](#) | [Duplicate](#)

This is the employers view of an editable library contract.

Library Contract: standard 5 wks hol

THIS EMPLOYMENT AGREEMENT is made the **[BID_ACCEPTED_DATE]**

BETWEEN:

- (1) **[EMPLOYER_COMPANY_NAME]** of **[EMPLOYER_COMPANY_ADDRESS]** ("the Employer");
- (2) and **[ARTIST_NAME]** of **[ARTIST_ADDRESS]** ("You").

This Agreement sets out the contractual terms of your employment with the Employer as follows:

1. **Date of employment**

1.1 It is anticipated that your employment will begin on **[EMPLOYMENT_START_DATE]** and will continue until **[EMPLOYMENT_END_DATE]** and is subject to a standard one-month probationary period. Your employment will be reviewed shortly before your contract end date with a view to renewal but this cannot be guaranteed.

2. **YOUR duties**

2.1 You are employed as a Freelance Visual Effects Artist. You will be informed as to your duties by The Managing Director. Your duties may be varied from time to time provided they are appropriate to your knowledge and status.

2.2 During your employment you will spend the whole of your time, attention and ability carrying out your duties with due care and attention.

3. **Standard of work**

You are required to reach a standard of work appropriate to your Position in the company. These standards will be set out by the Employer at the beginning of your employment.

4. **Working time and place**

4.1 Your hours will be 9.00am to 6pm (Monday to Friday)

4.2 You may be required to work outside these hours should it be necessary in order to complete the tasks you have been allocated. Regulation 4(1) of the Working Time Regulations 1998 (the "WTR") provides that an employee's average working time, including overtime, should not exceed 48 hours each week unless the employee agrees otherwise. In accordance with Regulation 5, you agree that Regulation 4(1) of the WTR will not apply to your employment. You or the Employer may at any time give three months written notice to withdraw this opt out.

4.3 Your principal places of work shall be **[EMPLOYER_COMPANY_ADDRESS]** or such other location as the Employer may from time to time determine. The Employer will give 1 week's notice of any permanent change of location.

5. **Salary**

5.1 Your salary of **[BID_CURRENCY]** **[BID_AMOUNT]** per **[BID_AMOUNT_FREQUENCY]**, will be paid monthly in arrears direct into your bank account. Salary shall be paid less all deductions required by law, including deduction of income tax and national insurance.

5.2 There is no pension payable in respect of the employment. Provided that you are eligible, the Employer will provide you with details of its designated stakeholder pension scheme ("SPS") to which you may elect to have access. The Employer will not make any contribution to the SPS on your behalf. The Employer makes no recommendations in respect of the SPS, nor does it make any representation or warranty as to its suitability for you.

6.etc

[Search](#)

[Advanced Search](#)

[Home](#)

[Artist A - Z](#)

[Profile](#)

[Bids](#)

[Projects](#)

[Shortlist](#)

[Contracts](#)

Library >

[DEFAULT](#)
[Standard 5wks Holiday](#)
[Another Contract](#)
[Sopecial Contract](#)

Live Bids >

[James_Dong](#)
[Andy_Rawling](#)
[Fred_Chapman](#)
[Dave_Spark](#)
[Andy_Middleton](#)

Finalized >

[James_Dong](#)
[Andy_Rawling](#)
[Fred_Chapman](#)
[Dave_Spark](#)
[Andy_Middleton](#)

This contract is associated with an open bid. If you edit the wording of this contract, the artist Dave Spark will be notified.

[Show Resolved Variables](#)

Open Bid Contract: Dave_Spark_13

THIS EMPLOYMENT AGREEMENT is made the [BID_ACCEPTED_DATE]

BETWEEN:

- (1) [EMPLOYER_COMPANY_NAME] of [EMPLOYER_COMPANY_ADDRESS] ("the Employer");
- (2) and [ARTIST_NAME] of [ARTIST_ADDRESS] ("You").

This Agreement sets out the contractual terms of your employment with the Employer as follows:

1. Date of employment

1.1 It is anticipated that your employment will begin on [EMPLOYMENT_START_DATE] and will continue until [EMPLOYMENT_END_DATE] and is subject to a standard one-month probationary period. Your employment will be reviewed shortly before your contract end date with a view to renewal but this cannot be guaranteed.

2. YOUR duties

2.1 You are employed as a Freelance Visual Effects Artist. You will be informed as to your duties by The Managing Director. Your duties may be varied from time to time provided they are appropriate to your knowledge and status.
2.2 During your employment you will spend the whole of your time, attention and ability carrying out your duties with due care and attention.

3. Standard of work

You are required to reach a standard of work appropriate to your Position in the company. These standards will be set out by the Employer at the beginning of your employment.

4. Working time and place

4.1 Your hours will be 9.00am to 6pm (Monday to Friday)
4.2 You may be required to work outside these hours should it be necessary in order to complete the tasks you have been allocated. Regulation 4(1) of the Working Time Regulations 1998 (the "WTR") provides that an employee's average working time, including overtime, should not exceed 48 hours each week unless the employee agrees otherwise. In accordance with Regulation 5, you agree that Regulation 4(1) of the WTR will not apply to your employment. You or the Employer may at any time give three months written notice to withdraw this opt out.
4.3 Your principal places of work shall be [EMPLOYER_COMPANY_ADDRESS] or such other location as the Employer may from time to time determine. The Employer will give 1 week's notice of any permanent change of location.

5. Salary

5.1 Your salary of [BID_CURRENCY] [BID_AMOUNT] per [BID_AMOUNT_FREQUENCY], will be paid monthly in arrears direct into your bank account. Salary shall be paid less all deductions required by law, including deduction of income tax and national insurance.
5.2 There is no pension payable in respect of the employment. Provided that you are eligible, the Employer will provide you with details of its designated stakeholder pension scheme ("SPS") to which you may elect to have access. The Employer will not make any contribution to the SPS on your behalf. The Employer makes no recommendations in respect of the SPS, nor does it make any representation or warranty as to its suitability for you.

6.etc

[Home](#)[Artist A - Z](#)[Profile](#)[Bids](#)[Projects](#)[Shortlist](#)[Contracts](#)**Library >**[DEFAULT](#)
[Standard 5wks Holiday](#)
[Another Contract](#)
[Sopecial Contract](#)**Live Bids >**[James_Dong](#)
[Andy_Rawling](#)
[Fred_Chapman](#)
[Dave_Spark](#)
[Andy_Middleton](#)**Finalized >**[James_Dong](#)
[Andy_Rawling](#)
[Fred_Chapman](#)
[Dave_Spark](#)
[Andy_Middleton](#)

You cannot edit this contract as it has been accepted by the artist, Fred Chapman

Accepted Bid Contract: Fred_Chapman_15

THIS EMPLOYMENT AGREEMENT is made the [\[BID_FINALIZED_DATE\]](#)

BETWEEN:

- (1) [The Moving Picture Company Ltd](#) of [127 Wardour Street, London. W1V 4NL](#) ("the Employer");
- (2) and [Fred Chapman](#) of [13 Biggin Hill Lane, Biggin Hill, Kent. BR7 9BR](#) ("You").

This Agreement sets out the contractual terms of your employment with the Employer as follows:

1. Date of employment

- 1.1 It is anticipated that your employment will begin on [19 November 2008](#) and will continue until [10th March 2009](#) and is subject to a standard one-month probationary period. Your employment will be reviewed shortly before your contract end date with a view to renewal but this cannot be guaranteed.

2. YOUR duties

- 2.1 You are employed as a Freelance Visual Effects Artist. You will be informed as to your duties by The Managing Director. Your duties may be varied from time to time provided they are appropriate to your knowledge and status.
- 2.2 During your employment you will spend the whole of your time, attention and ability carrying out your duties with due care and attention.

3. Standard of work

You are required to reach a standard of work appropriate to your Position in the company. These standards will be set out by the Employer at the beginning of your employment.

4. Working time and place

- 4.1 Your hours will be 9.00am to 6pm (Monday to Friday)
- 4.2 You may be required to work outside these hours should it be necessary in order to complete the tasks you have been allocated. Regulation 4(1) of the Working Time Regulations 1998 (the "WTR") provides that an employee's average working time, including overtime, should not exceed 48 hours each week unless the employee agrees otherwise. In accordance with Regulation 5, you agree that Regulation 4(1) of the WTR will not apply to your employment. You or the Employer may at any time give three months written notice to withdraw this opt out.
- 4.3 Your principal places of work shall be [127 Wardour Street, London. W1V 4NL](#) or such other location as the Employer may from time to time determine. The Employer will give 1 week's notice of any permanent change of location.

5. Salary

- 5.1 Your salary of [GBP 4000](#) per [Calendar Month](#) will be paid monthly in arrears direct into your bank account. Salary shall be paid less all deductions required by law, including deduction of income tax and national insurance.
- 5.2 There is no pension payable in respect of the employment. Provided that you are eligible, the Employer will provide you with details of its designated stakeholder pension scheme ("SPS") to which you may elect to have access. The Employer will not make any contribution to the SPS on your behalf. The Employer makes no recommendations in respect of the SPS, nor does it make any representation or warranty as to its suitability for you.

6.etc

[Search](#)

[Advanced Search](#)

[Home](#)

[Artist A - Z](#)

[Profile](#)

[Bids](#)

[Projects](#)

[Shortlist](#)

[Contracts](#)

Library >

[DEFAULT](#)

Standard 5wks Holiday

[Another Contract](#)

[Sopecial Contract](#)

Live Bids >

[James_Dong](#)

[Andy_Rawling](#)

[Fred_Chapman](#)

[Dave_Spark](#)

[Andy_Middleton](#)

Finalized >

[James_Dong](#)

[Andy_Rawling](#)

[Fred_Chapman](#)

[Dave_Spark](#)

[Andy_Middleton](#)

Editing Library Contract: standard 5 wks hol

Variable Substitutions

[Close this](#)

DATE_TODAY
EMPLOYMENT_START_DATE
EMPLOYMENT_END_DATE
EMPLOYER_CONTACT_NAME
EMPLOYER_COMPANY_NAME
EMPLOYER_COMPANY_ADDRESS
EMPLOYER_PHONE

ARTIST_FIRST_NAME
ARTIST_LAST_NAME
ARTIST_FULL_NAME
ARTIST_ADDRESS_INLINE
ARTIST_ADDRESS_CR
ARTIST_PHONE
PROJECT_LONG_NAME
PROJECT_SHORT_NAME

POSITION_NAME
BID_CURRENCY
BID_AMOUNT
BID_AMOUNT_FREQUENCY
BID_FINALIZED_DATE
BID_OPENED_DATE
BID_ACCEPTED_DATE

[Formatting guide >](#)

Library Contract: standard 5 wks hol

THIS EMPLOYMENT AGREEMENT is made the **[BID_ACCEPTED_DATE]**

BETWEEN:

(1) **[EMPLOYER_COMPANY_NAME]**
of **[EMPLOYER_COMPANY_ADDRESS]** ("the Employer");

(2) and **[ARTIST_NAME]** of **[ARTIST_ADDRESS]** ("You").

This Agreement sets out the contractual terms of your employment with the Employer as follows:

1. Date of employment

1.1 It is anticipated that your employment will begin on **[EMPLOYMENT_START_DATE]** and will continue until **[EMPLOYMENT_END_DATE]** and is subject to a standard one-month probationary period. Your employment will be reviewed shortly before your contract end date with a view to renewal but this cannot be guaranteed.

2. YOUR duties

2.1 You are employed as a Freelance Visual Effects Artist. You will be informed as to your duties by The Managing Director. Your duties may be varied from time to time provided they are appropriate to your knowledge and status.

2.2 During your employment you will spend the whole of your time, attention and ability carrying out your duties with due care and attention.

3. Standard of work

You are required to reach a standard of work appropriate to your Position in the company. These standards will be set out by the Employer at the beginning of your employment.

4. Working time and place

4.1 Your hours will be 9.00am to 6pm (Monday to Friday)

4.2 You may be required to work outside these hours should it be necessary in order to complete the tasks you have been allocated. Regulation 4(1) of the Working Time Regulations 1998 (the "WTR") provides that an employee's average working time, including overtime, should not exceed 48 hours each week unless the employee agrees otherwise. In accordance with Regulation 5, you agree that Regulation 4(1) of the WTR will not apply to your employment. You or the Employer may at any time give three months written notice to withdraw this opt out.

4.3 Your principal places of work shall be **[EMPLOYER_COMPANY_ADDRESS]** or such other location as the Employer may from time to time determine. The Employer will give 1 week's notice of any permanent change of location.

5. Salary

5.1 Your salary of **[BID_CURRENCY]** **[BID_AMOUNT]** per **[BID_AMOUNT_FREQUENCY]**, will be paid monthly in arrears direct into your bank account. Salary shall be paid less all deductions required by law, including deduction of income tax and national insurance.

5.2 There is no pension payable in respect of the employment. Provided that you are eligible, the

Employer will provide you with details of its designated stakeholder pension scheme ("SPS") to which you

When editing any editable contract - show the list of available variables

[Save](#)

[Save a duplicate](#)

or [Cancel](#)

Contracts Logic

CONTRACT ASSOCIATIONS

2 types of contract association:

Library Contracts

(Associated with an Organization)

Bid Contracts

(Associated with a Bid)

Library Contracts are templates. The default library contract may not be deleted because the user should always have at least one contract from which to instantiate new contracts.

Bid Contracts belong to a bid. There is a one to one association between a bid contract and a bid.

Section	Bid Status	Name	Delete	Edit	Copy / Source	Flattened
Library	N / A	default contract	No	No	Yes	No
	N / A	library contract 1	Yes	Yes	Yes	No
	N / A	my_library contract	Yes	Yes	Yes	No
	N / A	another_library_contract	Yes	Yes	Yes	No
Live Bid	Open	James_Smith_004	With Bid	Yes	Yes	No
	Accepted	Andy_Rawling_086	With Bid	No	Yes	No
	Accepted	Andy_Rawling_092	With Bid	No	Yes	No
	Open	Dave_Spark_775	With Bid	Yes	Yes	No
	Open	Chirag_Shah_024	With Bid	Yes	Yes	No
Finalized	Finalized	James_Smith_004	No	No	No	Yes
	Finalized	Andy_Rawling_086	No	No	No	Yes
	Finalized	Andy_Rawling_092	No	No	No	Yes
	Finalized	Dave_Spark_775	No	No	No	Yes
	Finalized	Chirag_Shah_024	No	No	No	Yes

NEW BID

When an employer creates a new bid, he selects a **source** contract. The list of available source contracts consists of all un-flattened contracts (library / live bids).

A copy of the source contract is made and named <artist>_<bid_id>

This new contract is attached to the new (**open**) bid. If the bid is deleted, the contract is also deleted.

OPEN BID

A bid is created in the open state. All the while the bid is open, the associated contract text may be edited by the employer's rep.

Edits to the contract are considered changes to the bid, therefore, like any other change to the bid, a notification that the text has been changed is appended to the message log for the bid.

An open bid is not flattened. The variables remain in tact. The artist or employer may choose to view the contract with variables resolved (where possible), but the underlying object is never flattened until it is finalized.

ACCEPTED BID

When a bid is accepted by an artist, the bid can no longer be changed, therefore the associated contract may not be edited.

The variables in this contract are left unresolved.

FINALIZED BID

When a bid is finalized, all contract variables are resolved and the bid is considered "**FLATTENED**".

A finalized bid contract is permanent and can never be changed in any way.

Bid Process

An organization has many projects.
 A project has many positions
 A position has a number of vacancies. In the example:

MPC has 5 vacancies for the position of 3d modeler. They also need 2 project managers and 3 texture artists.

PIX need 2 animators, 4 painters and 3 modelers.

Green = filled. White = not filled

Artists and representatives may change the status of bids in different ways, depending on the current status of the bid.

status	rep actions	artist actions
Open	Retract (= delete)	Accept / Decline
Accepted	Finalize / Retract	Re-Open / Decline
Finalized	(no action)	(no action)
Declined	(no action)	Delete / Re-Open

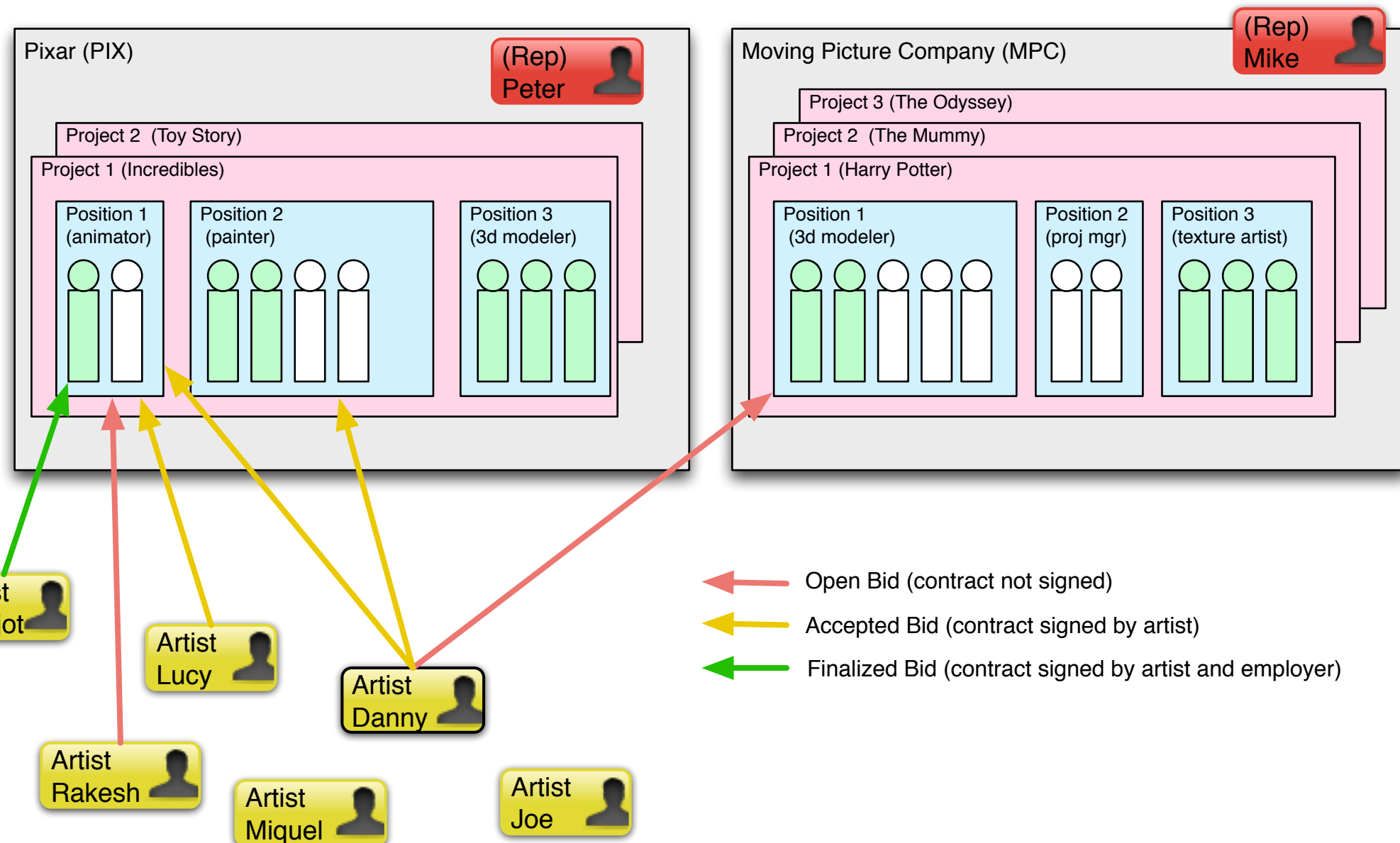

Brief description of the bid process.

When a representative makes a bid for an artist, he must set the project and position. There must be vacancies available for that position. In the above example, Mike at MPC is blocked from making a bid to any artists for the position of "harry potter - texture artist" because the 3 vacancies have been filled. He may bid for artists for project manager, or 3d modeler.

Whenever a bid changes status, some tests are made to ensure that the change is valid, and if so, the parties are notified of the change. If status is changed to Finalized, and other employers or artists are affected, some follow-up actions may be taken. Details below.

A bid is CREATED with status: "OPEN"

Example: Peter bids for Danny for the position Painter.
 Danny and Peter both Receive a "new bid" email notification with all the bid details. **Subject: Pix Incredibles Painter [bid id]**
 Peter may have written an introduction message with the bid. This will also be appended to the same email thread.
 Peter may not make another bid for the same artist for the same position.

While the bid is open, Peter may make other edits, for example, he may change the price, or the dates etc. These changes are not status changes.

Only the representative, may make changes to the bid details. The artist may not change details of a bid. If the artist wants the bid details to be changed, he may send a message (using the bid message thread) to request a change. For example ("I can't start work on the 8th, please change the start date to the 15th");

There is a contract attached to the bid. ~~It may be the same contract shared with other open bids.~~ The representative may only change wording in the contract while the bid is "open". A notification message is appended to the thread - e.g. "Contract wording Changed [date time]".

Peter, the rep, may RETRACT the bid if he changes his mind.

Retracting a bid means the bid is immediately **deleted**.

The artist, Danny, may ACCEPT or DECLINE an open bid.

When he accepts, the bid status is changed to **accepted**, and messages are logged. He is advised that he is entering a legally binding contract with the employer, and is asked to click a button (electronic signature) Peter may no longer make changes to the details of the bid (price, dates, etc.). He may no longer make changes to the contract attached to the bid.

When Danny declines a bid, the status is changed to **declined**. It is **not deleted** immediately. All the while the bid remains in the declined state, the rep, Peter, is blocked from making another bid to Danny for the same position. Only Danny, the artist, may delete or re-open a declined bid.

When the bid is in the declined state, the artist may either DELETE or RE-OPEN the bid.

If re-opened, status is changed to **OPEN** and the employer may edit the details again. Notifications are sent.

When the bid is in the accepted state, the rep may either RETRACT or FINALIZE the bid.

As before, retracting simply deletes the bid.

When the bid is in the accepted state, the artist may either DECLINE or RE-OPEN the bid.

As before, declining the bid blocks new bids for the same position
 If the bid is re-opened, the rep may again edit the details of the bid.

Finalizing a bid.

When a rep clicks the finalize button, he is taken to our payment gateway to pay our commission. This is the first part of the validation, so the status does not change to finalized until the payment has cleared. If it doesn't clear, no change is made.

If the payment clears the status is changed to finalized.

If the artist has other bids from other organizations, or bids from the same organization for other positions, and those bids' start and end dates overlap the bid that has just been finalized, they are automatically declined on behalf of the artist. An example - please refer to diagram above, -- Danny has been bid for three positions, 1 at MPC and 2 at Pixar.

If he accepts the bid for animator at Pixar, the bids for painter at pixar and modeler at MPC are both declined automatically. Messages are appended to the threads for those bids - and echoed by email notifications.

Also, if the finalization of the bid means the last vacancy is filled, then bids for other artists for that position are automatically retracted. In the above example, Peter, the rep, had bid for 4 artists for the position "animator". There were 2 vacancies only, so the first 2 artists to be finalized will fill the position. Sanjot has been finalized already. Rakesh has not yet accepted, so he can't be finalized. Lucy and Danny are the only two candidates who have accepted the position. Peter, the rep chooses Danny - so Lucy and Rakesh are both notified that the position has been filled.

Peter could have waited for Rakesh to Accept, but he would be running the risk of losing Danny and Lucy to another employer. He could also edit the position to increase the number of vacancies, then hired both and left one vacancy open for Lucy. Finally, instead of hiring Danny, he could have edited the number of vacancies down to 1. By doing this, the position would be filled (he already has Sanjot) so again, everyone else's bids would be retracted and they would be notified.

Finalized bids are never deleted.

All other bids are deleted if the current date is passed the bid start date. (? might change to "passed end date" - to allow artist to leave declined bids so that employers are blocked from new bids)

Positions are never deleted if they ever had a finalized bid associated with them.

Positions or Projects that never had a finalized bid may be deleted any time (bids will be retracted and parties notified).

Entity Relationships

- artist profile
- employer stuff
- bid stuff
- all users
- master

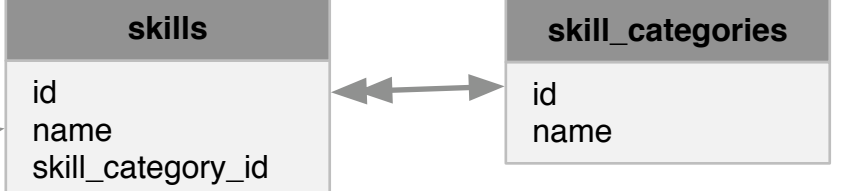
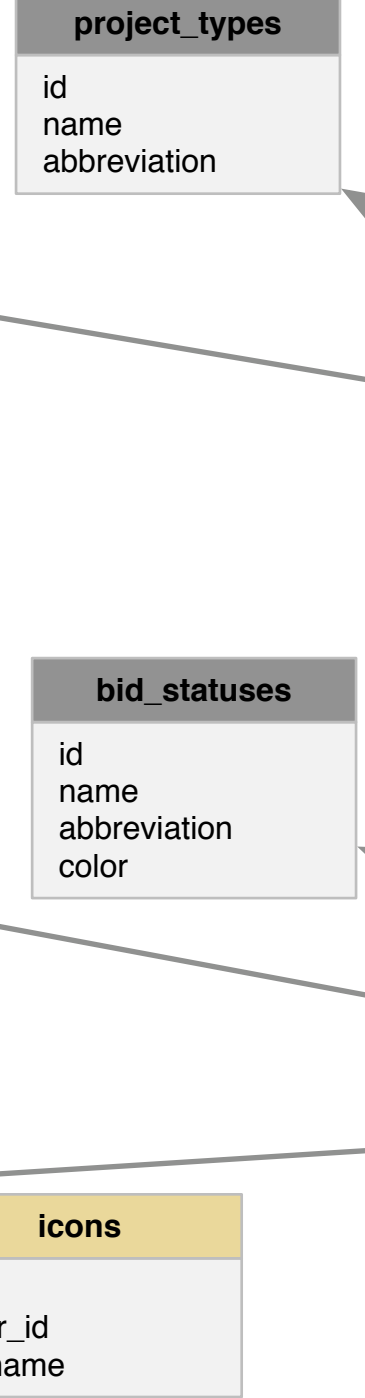
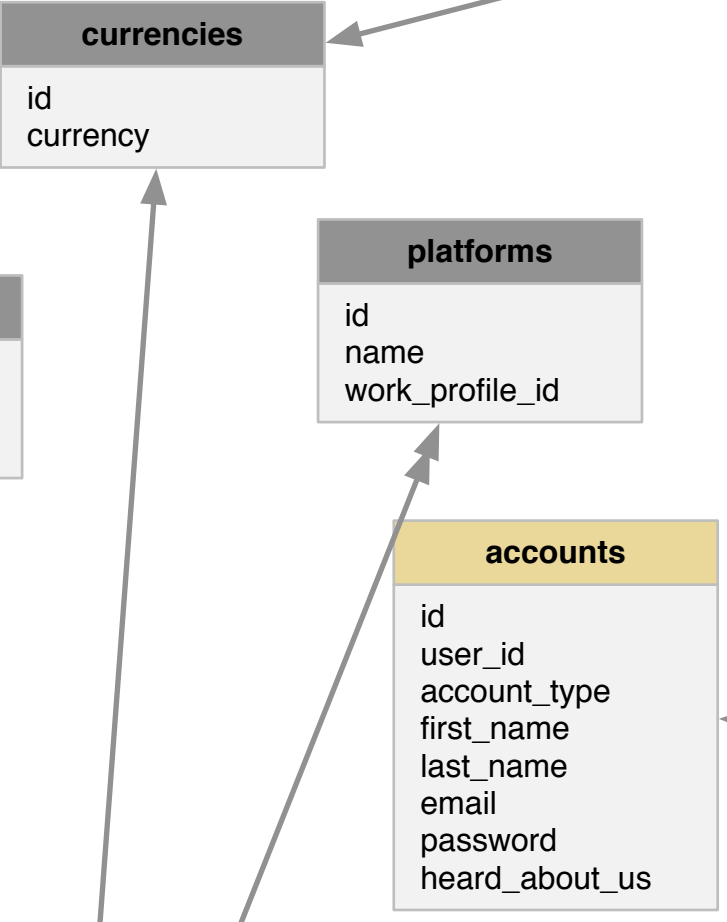
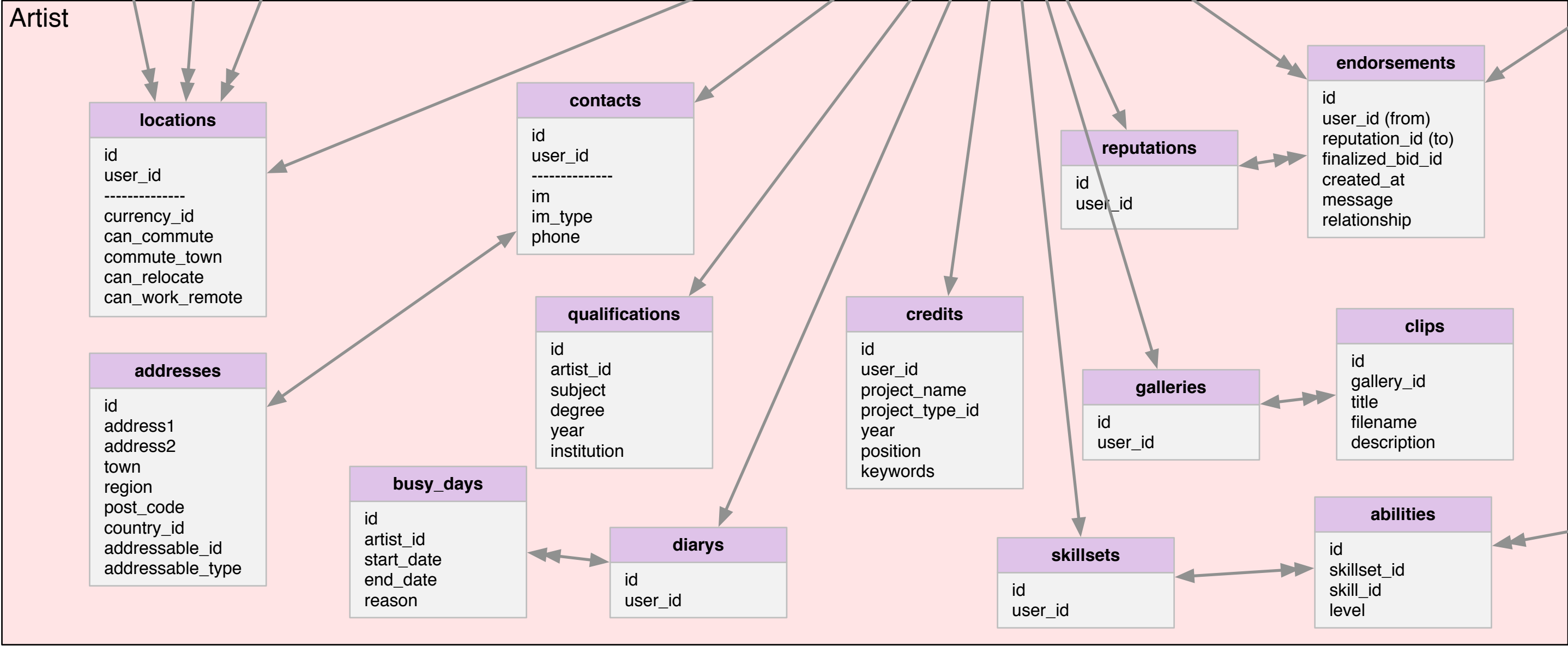
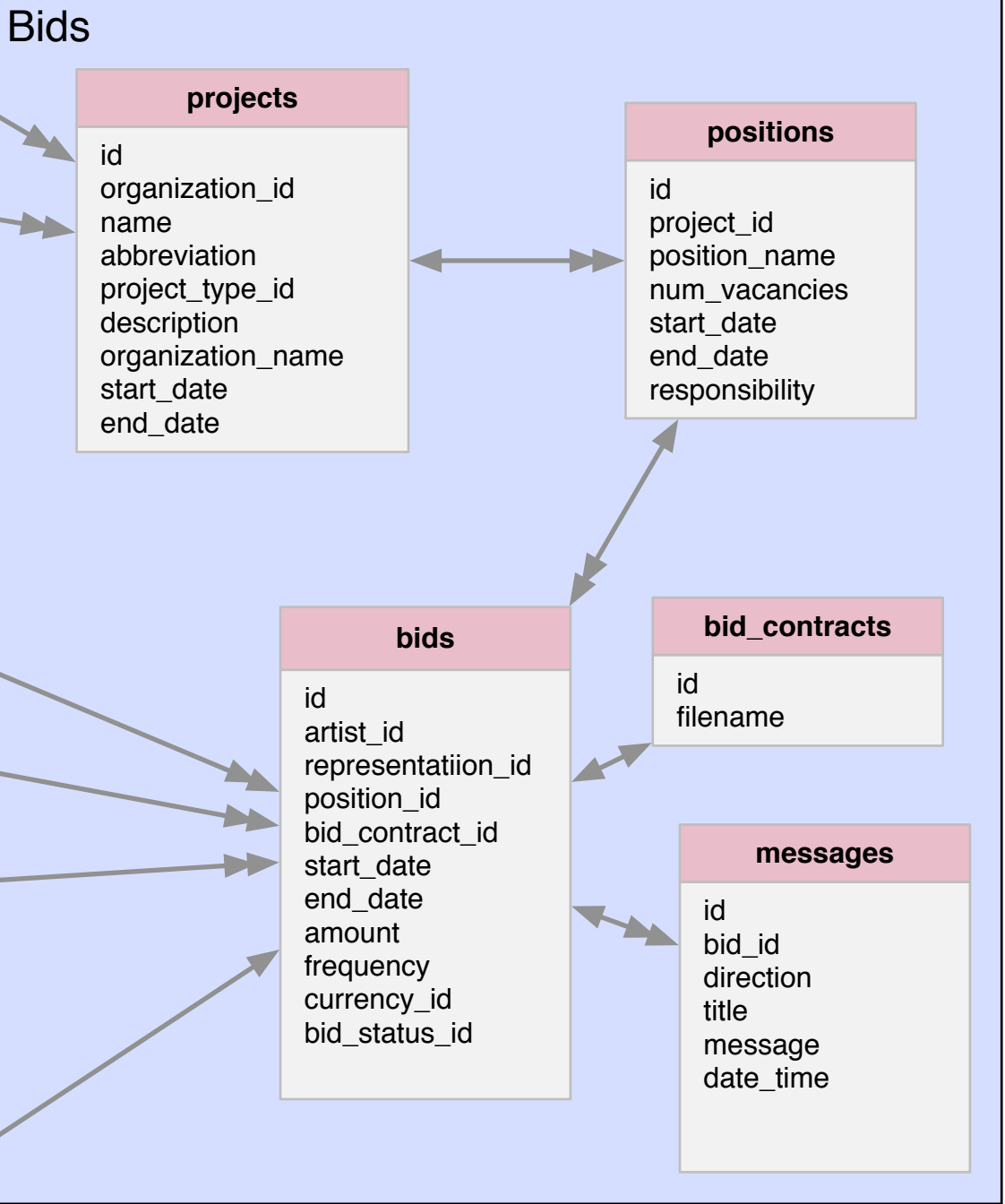
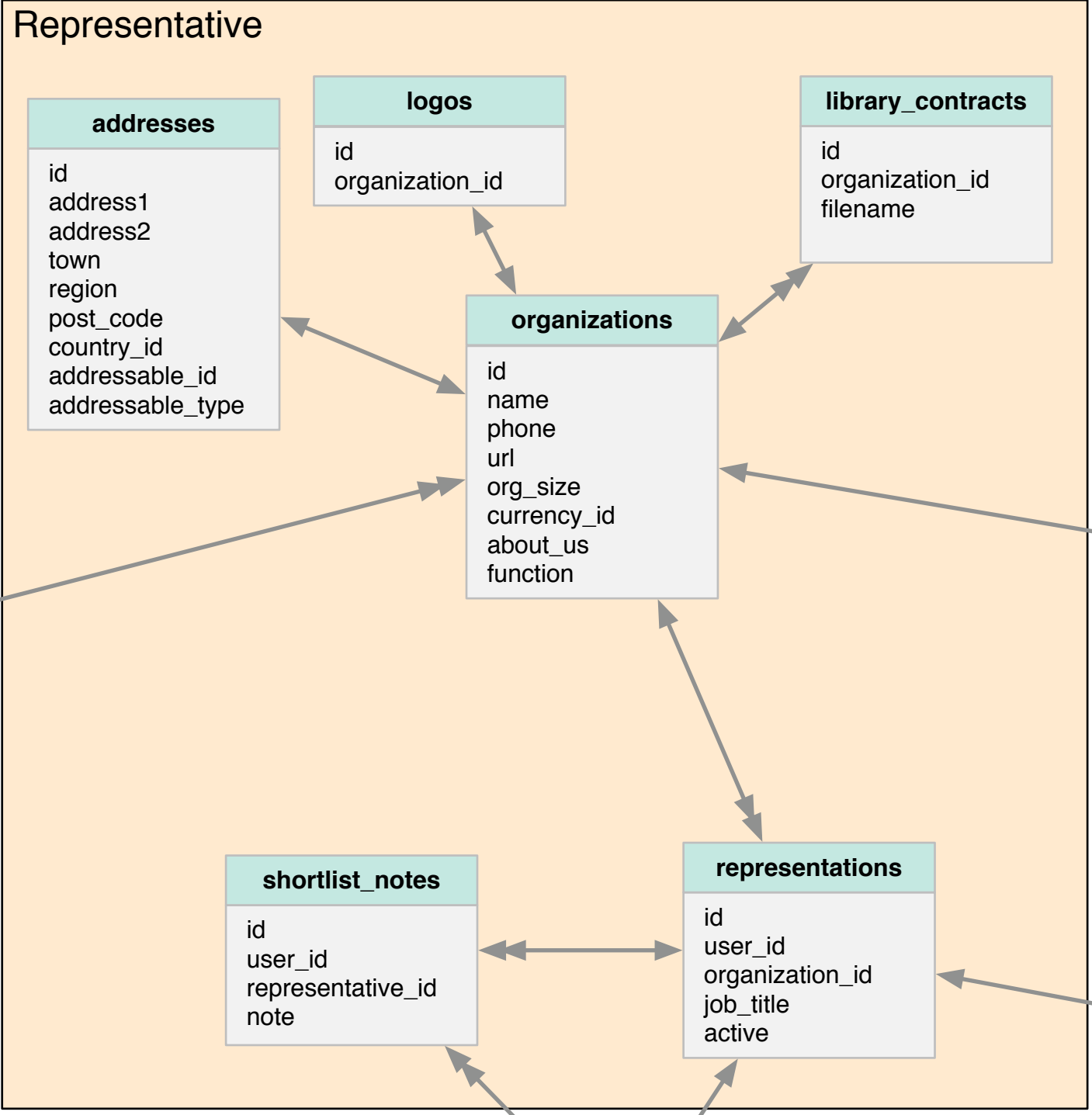

Deleting Users

artist profile
employer staff
bid stuff
all users
master

This page is the same as the entity relationships page, but with overlays to show what to delete when a user has their artist or representative profiles removed.

Delete the only representative (primary) and Organization

Delete organization - including contracts library, logos, address etc.

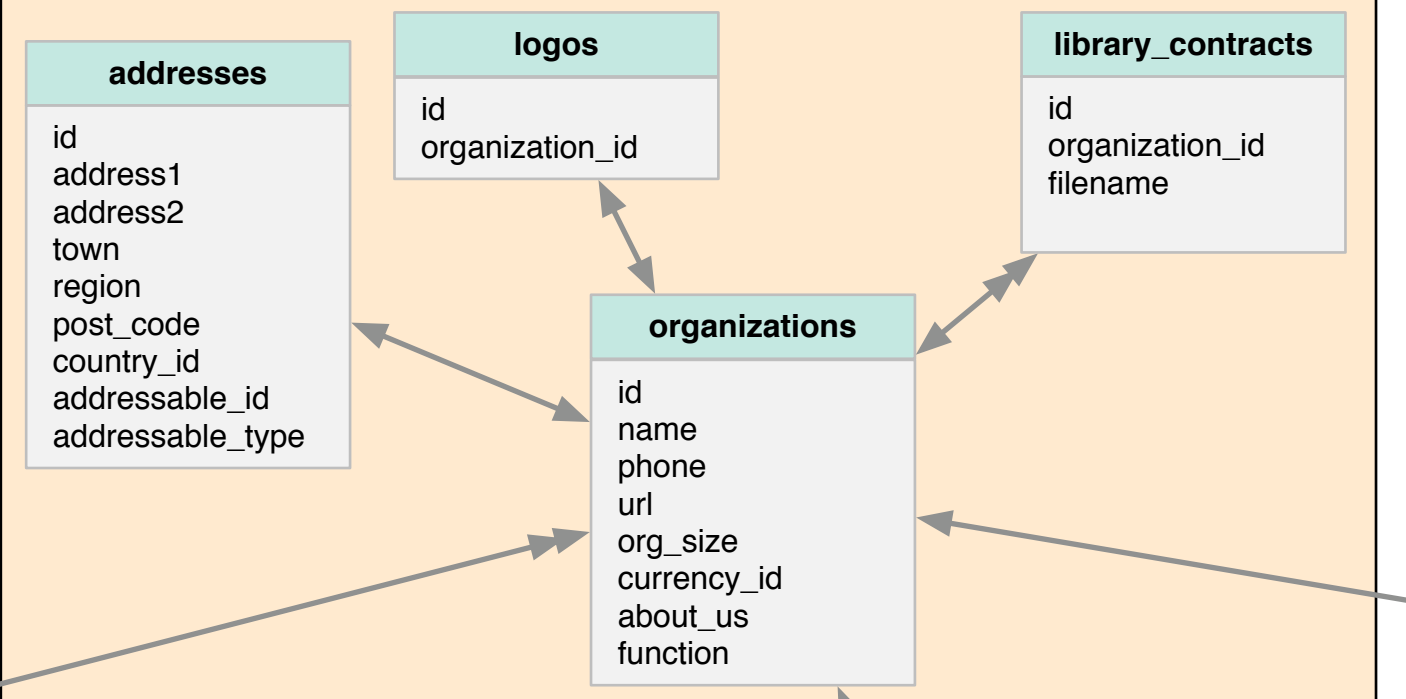

Delete a representative when the organization has more than one representative

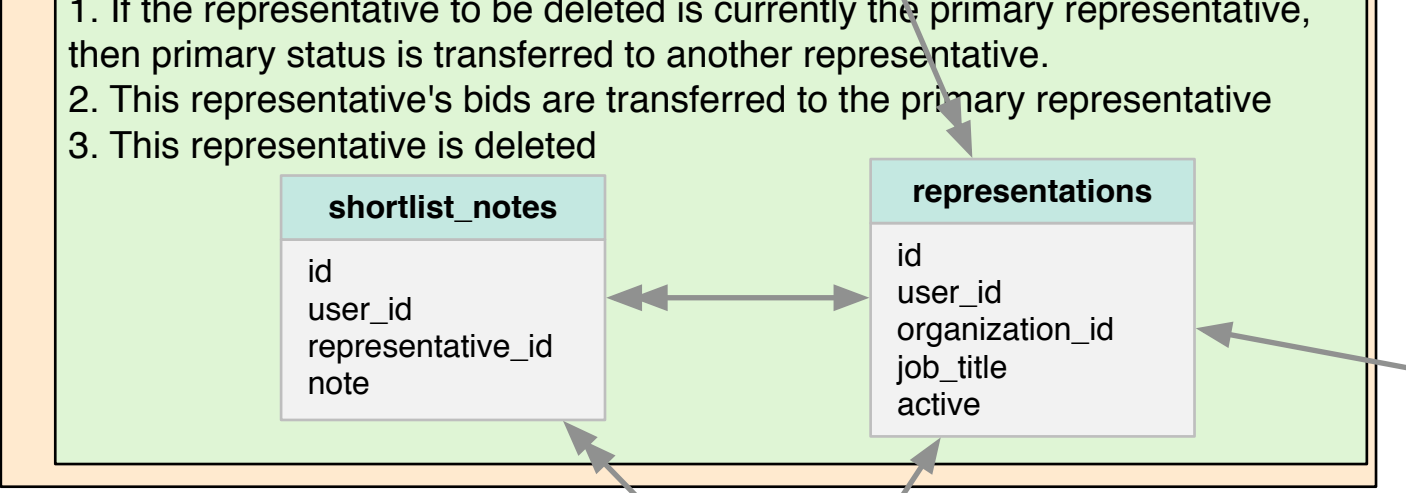

Delete bids when deleting organization

Delete Open, Accepted, and Declined bids
Delete empty positions and projects (those with no finalized bids)
Finalized Bids are kept - along with associated messages, contracts, positions, and projects.

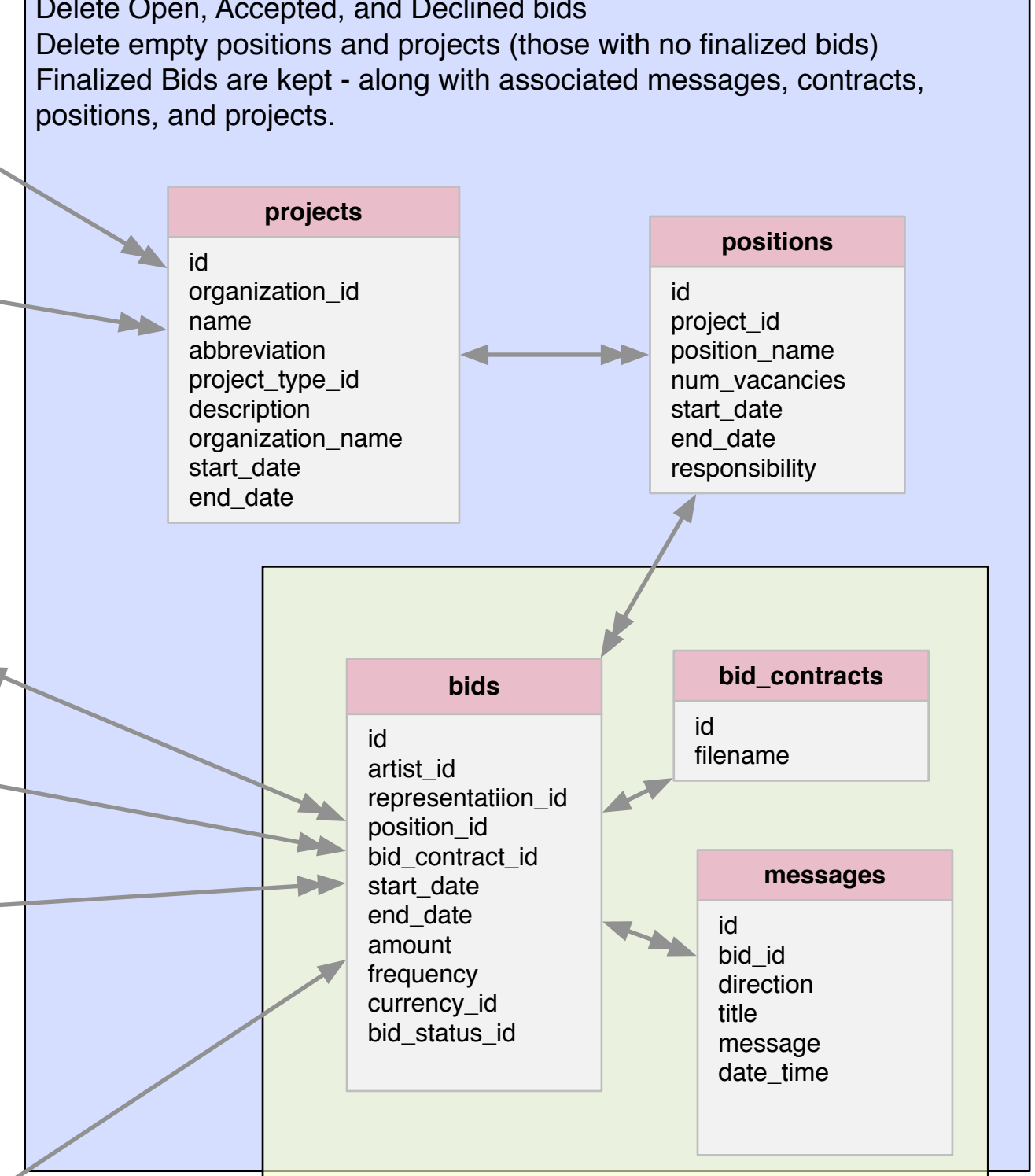

Delete bids when deleting artist

Delete Open, Accepted, and Declined bids.
Finalized Bids are never deleted - they are kept, along with associated message, contracts, positions, and projects.

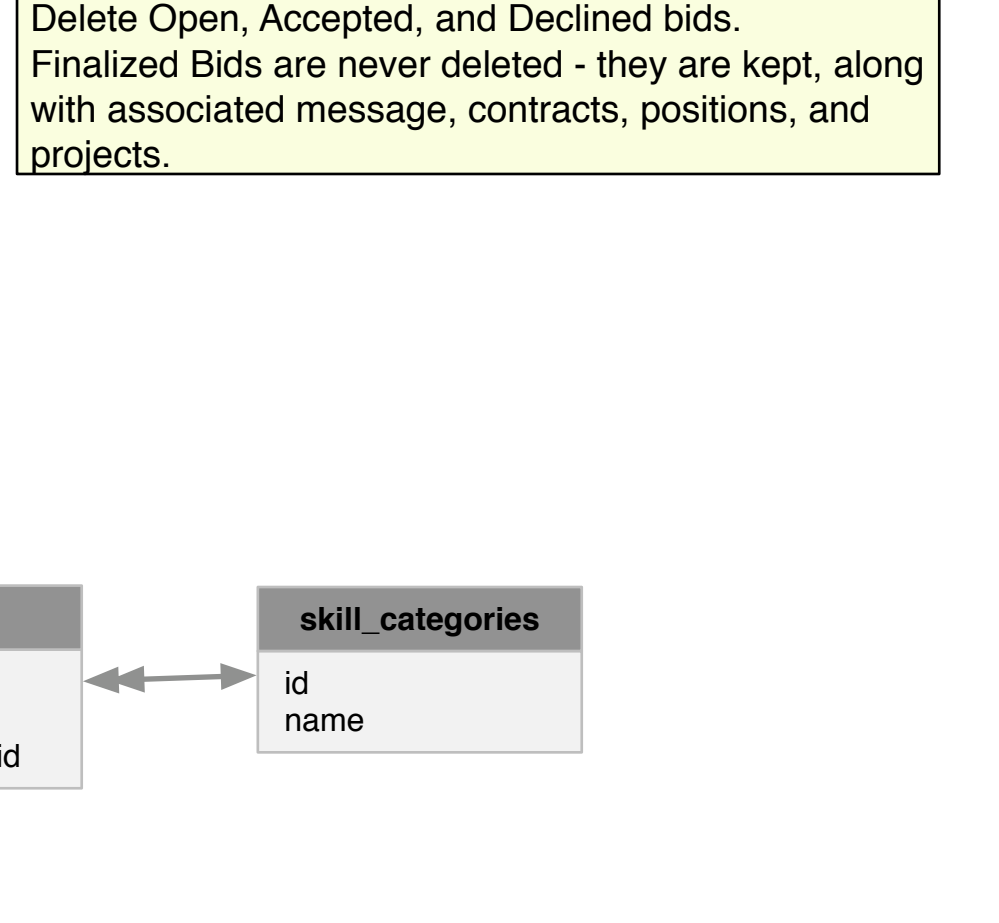

Delete an artist

Open, Accepted, Declined bids are deleted
All enclosed profile records are deleted

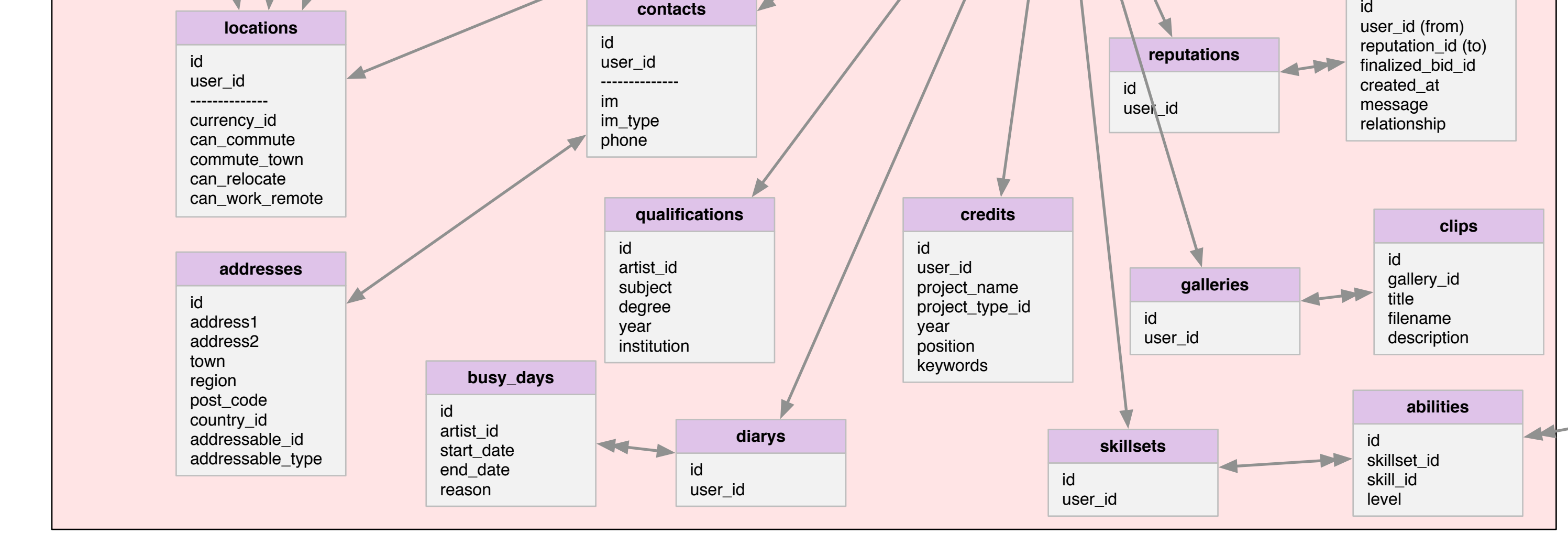

DELETE REPRESENTATION

A user who is a representative of an organization may have her representation deleted.
1. She may delete her representation herself on her account page, by changing her account type to "artist"
2. (Currently she may also decide to no longer represent an organization on her "edit representation" page - This functionality will be removed in phase 2)

3. If she is not the primary representative, then she may also have her representation deleted by the primary representative on the "edit organization" page (for example - she may be fired). In this case, if she is a representative ONLY (not an artist), then her entire account will be deleted as she has no data worth keeping. She can of course sign up again

When her representation is deleted she must not have any live bids. Any bid that is not yet finalized, we call live:

```

def all_live_bids
  Bid.find_by(:status[:declined] || :open || :accepted)
end
  
```

If she is NOT the last representative for her organization, then ownership of her bids will be transferred to another representative. If she is the primary representative, and there are other representatives, then her primary status will also be transferred to another representative. In phase 2 we will also make a facility on the "organization edit" page for transferring primary status to another representative.

If she is the only representative for her organization, then the organization must be deleted. If the organization is deleted Live bids must be retracted (deleted) along with their messages and contracts.

The pseudocode below explains the logic in the context of a before_delete callback on the Representation class

```

class Representation
  def before_delete
    bids = self.find_bids(:live) #not finalized
    if self.organization.representations.count > 1
      other_rep = self.organization.first_representation_other_than(self)
      other_rep.primary = true unless other_rep.primary?
      bids.each {|b| b.representation = other_rep} # transfer bids to other rep
    else
      bids.each {|b| b.delete}
      self.organization.delete
    end
  end
end
  
```

In the first half of the above "if" block, there is a change of bid ownership. This change to the bid (like any other) is logged in the message thread (and hence to email notification too). This means, the bidder will find out by email if a different representative is handling the bid.

In the "else" part, there is a call to Bids::delete (means same as retract). Bids are not just deleted without a trace. When a bid is deleted, it will have its own code (before_delete callback) to handle tidying up, which will include an email notification to the artist.

Normally, a representative cannot delete a declined bid, because the artist declined the bid to stop the representative from re-bidding for the same position. However, if the organization is being deleted altogether, then declined bids must also be deleted.

Additionally, if an organization is deleted, then we check the organization's projects and positions to see if there are any finalized bids attached. We never delete finalized bids, and we never delete projects or positions with finalized bids associated. We delete all other projects and positions when the org is deleted.

pseudocode below explains this process

```

class Organization
  user_id (from)
  def before_delete
    self.projects.each do |project|
      project.positions.each do |position|
        position.all_live_bids.each do |bid|
          bid.delete
        end
        if (position.finalized_bids.count == 0) then
          position.delete
        end
      end
      if (project.positions.count == 0) then
        project.delete
      end
    end
  end
end
  
```

DELETE ARTIST

The only way an artist may delete her artist status is on her account page, by changing her account type to "employer". (In phase 2 we will add a delete button on the account page)

When a user loses artist status, the following profile fields will be deleted: [location, contact, qualification, diary, credit, skills, media, reputation]
Additionally, any endorsements this artist has made for other artists will be deleted.

Declined, Open or Accepted bids, will be deleted. (finalized bids are never deleted)

Also, we will notify the employer that the bids have been deleted. Referring to the diagram on Bid Process page (page 1), we see that an artist can change status of open or accepted bids to declined, and he can delete declined bids. Whenever any change is made to a bid, the changes should be entered in the message thread (which means they will also be sent as email for both parties)

So - when deleting artist status from a user's account - the code in the before_delete callback should delete live bids.

```

class User
  def before_delete
    if (artist?) then
      user.all_live_bids_for_me.each do |bid|
        bid.delete
      end
    end
  end
end
  
```

Before a bid is deleted, the employer should be notified - therefore:

```

class Bid
  def before_delete
    if (current_user == self.artist) then
      # send email notification to both parties "Bid has been deleted by artist"
    end
    if (current_user == self.representative) then
      # send email notification to both parties "Bid has been deleted by rep"
    end
  end
end
  
```